

 **EFKA** | your partner
in frames

Catalogue 





Global Office

EFKA B.V.
De Meerpaal 10
9206 AJ Drachten
The Netherlands

+31 512 47 27 21
sales@efka.nl
www.efka.nl

Regional Office

EFKA Frame Solutions Ltd.
Unit 25, Sycamore Road
Trent Lane Industrial Estate
Castle Donington, DE74 2NP
United Kingdom

+44 1332 228 150
sales@efka.co.uk
www.efka.co.uk

Get to know EFKA

YOUR PARTNER IN FRAMES

Our company was founded in 1888 as a wholesaler of wooden frames. In 2009, we started the production of aluminium textile frames. Since the introduction of these frames, we have experienced an unprecedented growth. From our production locations in the Netherlands and United Kingdom, we now deliver our products to all European countries and far beyond.

We are the specialist in aluminium textile frames. We only supply our products through resellers. These are distributors, large format printers, sign makers as well as stand and interior builders. We have a wide range of profiles in which fabrics or printed textiles can be fitted. That means that there is a suitable profile, for every application. The textile frames are available with and without illumination. They can be mounted on the wall, placed freestanding using baseplates or suspended from the ceiling.





What sets us apart?

THE SPECIALIST IN ALUMINIUM FRAMES



Leader in the European market



Within ten years, we have become European market leader in aluminium textile frames. As a company, we stand for innovation, quality and service.



Customised solutions



We can create any type of frame with seven double mitre saws, a CNC and a bending machine. In combination with our extensive range of profiles, there is always a suitable solution.



Sizeable inventory



We have more than 350 km of aluminium profiles in stock. In combination with a high production capacity, this ensures short delivery times and excellent service.



Worldwide delivery



We deliver our aluminium frames worldwide. With our customer service in three different languages, we can also provide an excellent and accessible service abroad.



The advantages of **ALUMINIUM FRAMES**



Available in any desired size

Each frame is custom made for you.



Interchangeable fabrics

Change the textile print or fabric quick and easy and create a new look in a room in no time.



Compact packaging

The installation of a textile frame is quick and easy. This makes compact packaging possible, allowing affordable transport.



Aluminium is 100 percent recyclable

All products can be returned to our company at the end of their lifecycle for a second life.

Textile print with
silicone tendon

Quick and
easy installation



8

TEXTILE FRAMES

1.1	Single-sided	12
1.2	Double-sided	24
1.3	Outdoor	32
1.4	Keder	34

38

LED FRAMES

2.1	LED technologies	42
2.2	Single-sided	50
2.3	Double-sided	54
2.4	Dynamic LED	60
2.5	Tunable white	64
2.6	Pop-up LEDbox	66

70

CURVED FRAMES

3.1	Non-illuminated	76
3.2	Illuminated	78

80

3D FRAMES

4.1	Non-illuminated	86
4.2	Illuminated	98

102

PANEL FRAMES

5.1	Panel hanging	104
5.2	L-shape	106

108

ACOUSTICS

6.1	Absorption value	110
-----	------------------	-----

112

PRODUCT OVERVIEW

7.1	Profiles	114	7.6	Wall mounts	133	7.11	Desk clamps	137
7.2	Acoustics	125	7.7	Ceiling mounts	134	7.12	Other	137
7.3	Locksets	126	7.8	Corners	134			
7.4	Extension sets	128	7.9	Connectors	135			
7.5	Baseplates	130	7.10	Tension sets	136			

112

LED COMPONENTS

8.1	LED strips and panels	141
8.2	Drivers	145
8.3	Controllers	146
8.4	Cables	147
8.5	LED spots	148



TEXTILE FRAMES

We have a wide range of aluminium textile frames, both single and double-sided. These frames allow you to change your advertising quickly and easily. An aluminium textile frame ensures high attention value, is durable and versatile. An aluminium textile frame can be mounted on the wall, placed freestanding using baseplates or suspended using suspension cables. A textile frame is lightweight and designed for years of intensive use.

1.1	Single-sided	12
1.2	Double-sided	24
1.3	Outdoor	32
1.4	Keder	34





Art Heroes





Textile frames

1.1 SINGLE-SIDED

Our single-sided textile frames can be attached to the wall or suspended from the ceiling. Attach the frame to the wall with screw fastening or use wallmounts. Ceiling mounts can be used to suspend a frame from the ceiling.



Eco 15

The most cost-effective profile for wall mounting.

✓ Optional: pre-drilled



Simple 19

A popular budget profile for wall mounting.

✓ Optional: pre-drilled



Slim 25

A sturdy and cost-effective profile for wall mounting.

✓ Optional: pre-drilled

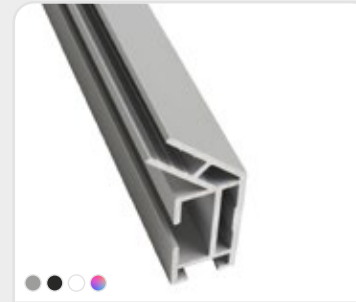

Heavy 26 45°

Wall profile that gives the print a floating effect.



Heavy 27

An extra strong profile for wall or ceiling mounting.



Single 50

A sturdy, single-sided profile that can be used in combination with acoustic material.



Cabinet 30

An affordable profile that is suitable for installation in a niche or frame.

All our profiles have a white label product sheet. Download it from the product page.



Quick and easy

MOUNTING OPTIONS

The installation of a textile frame is quick and easy. By simply connecting the corners and placing the textile print in the frame, the desired expression is made in no time. This makes compact packaging possible, allowing affordable transport of large formats.

Three attachment options

- ✓ Wall mounting
- ✓ Suspended from the ceiling
- ✓ Built-in



1. Connect the corners

Slide the lockset into the profile and tighten the screws to connect two profile parts and create a corner.



2. Place the frame

Mount the frame directly onto the wall or by using wall mounts. Hanging from the ceiling is also an option.



3. Attach the textile print

First attach the silicone tendon in the corners of the groove. Then press the print into the rest of the groove.

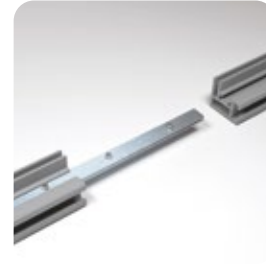

Extend the frame - optional

Long lengths are often delivered in two or more parts. The different parts can easily be assembled with the corresponding extension set.

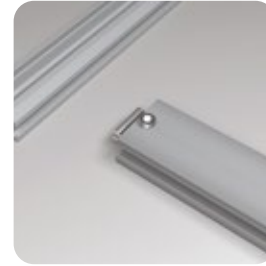

Reinforces the frame - optional

To guarantee the stability of large format frames, stabilizers get mounted in the frame that acts as reinforcement.

Did you know that all our frames come with a QR code that links to the white label installation manual?



Attachment option 1

DIRECT WALL MOUNTING

Mount the textile frame directly on the wall. To simplify the installation, the frame can also be supplied with pre-drilled holes, called punch holes. This makes the pre-drilled frame quicker to install.



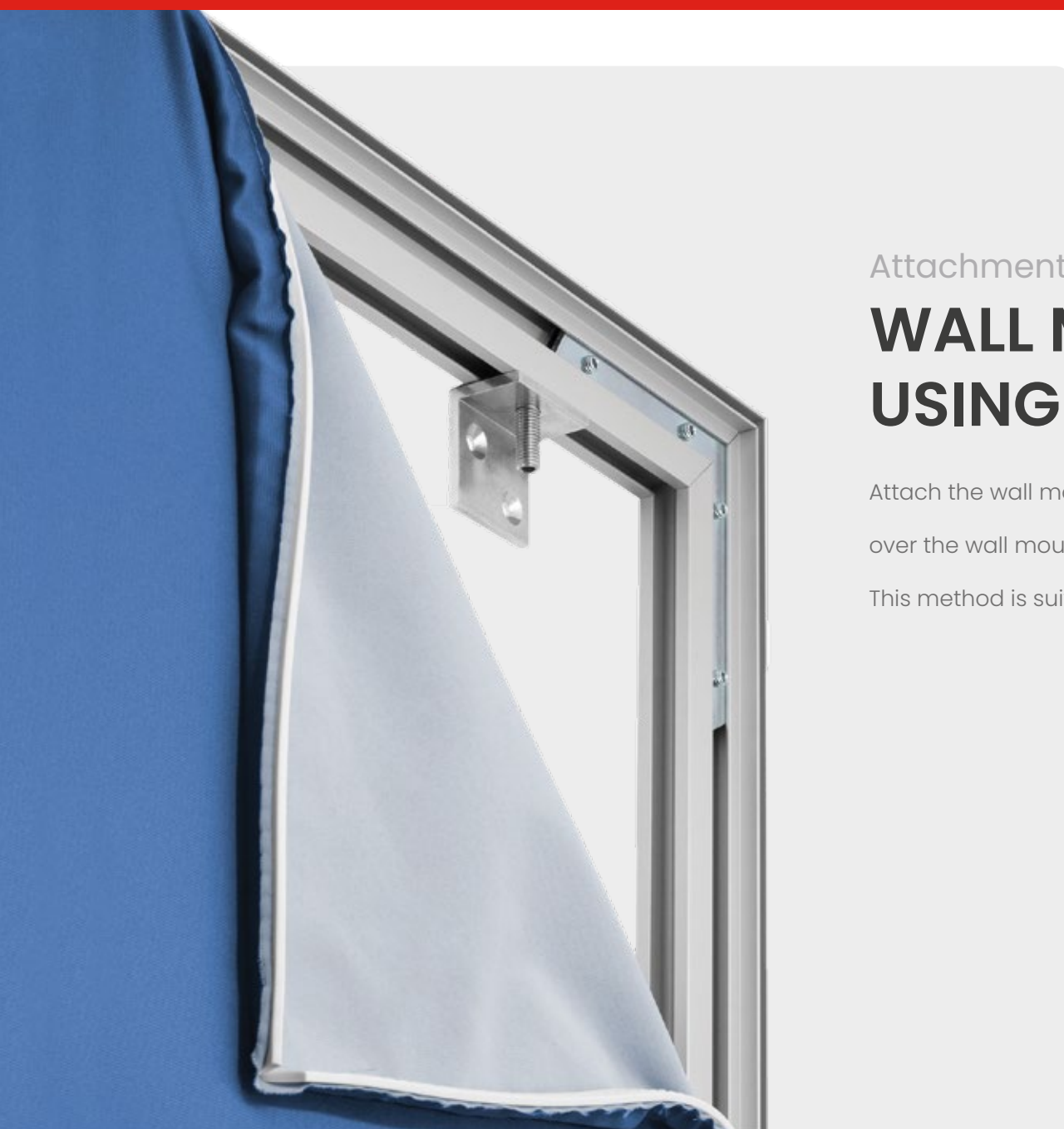

Attachment option 2

WALL MOUNTING BY USING WALL MOUNTS

Attach the wall mounts on the wall first. Then lift the whole textile frame over the wall mounts and rest it on the brackets in the designated track.

This method is suitable for the **Slim 25**, **Heavy 26 45°** and **Heavy 27** profile.

*See page 133 for
all wall mounts* 





Attachment option 3

SUSPENDED WITH CEILING MOUNTS

The **Slim 25** and **Heavy 27** frame can be suspended by installing ceiling mounts, which can be ordered separately.

*See page 134 for
all ceiling mounts* 



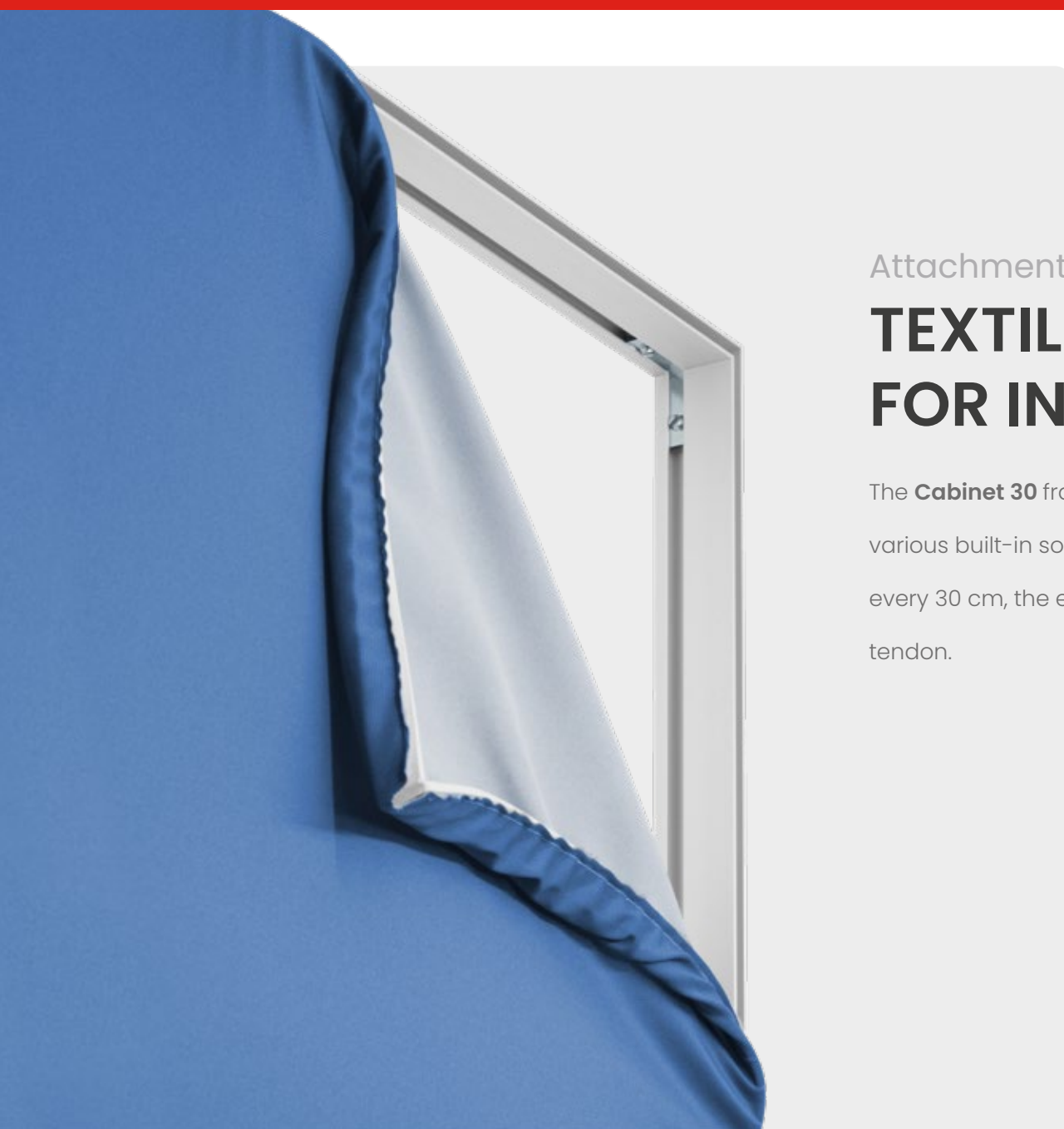

Attachment option 4

TEXTILE FRAME FOR INSTALLATION

The **Cabinet 30** frame is a specially designed textile frame that is suitable for various built-in solutions. By drilling the frame to the inside of the niche or frame every 30 cm, the entire opening can be covered by the textile print with its silicone tendon.





Textile frames

1.2 DOUBLE-SIDED

A double-sided textile frame can be used both freestanding and suspended. Create eye-catching displays in stores and showrooms or attractive partition walls that look perfect in any office.



Double 44

The most popular profile for a freestanding and suspended application.

✓ Open and closed



Double 50

A sturdy and versatile profile that can be used in combination with acoustic material.

✓ Open and closed



Double 80

An extra-strong double-sided profile suitable for extra-large formats.

✓ Open and closed



Double 100

A double-sided profile for a freestanding and suspended application.

All our profiles have a white label product sheet. Download it from the product page.



Quick and easy

MOUNTING OPTIONS

The installation of a textile frame is quick and easy. By simply connecting the corners and placing the textile print in the frame, the desired expression is made in no time. This makes compact packaging possible, allowing affordable transport of large formats.



1. Connect the corners

Slide the lockset into the profile and tighten the screws to connect two profile parts and create a corner.



2. Place the textile print

First attach the silicone tendon in the corners of the groove. Then press the print into the rest of the groove.



3. Attach the frame

Place the frame freestanding or hanging with the appropriate installation options.



Extend the frame - optional

Long lengths are often delivered in two or more parts. The different parts can easily be assembled with the corresponding extension set.



Reinforces the frame - optional

To guarantee the stability of large format frames, stabilizers get mounted in the frame that acts as reinforcement.



Blockout fabric - optional

The blockout fabric prevents sunlight, artificial light and stabilizers from shining through the fabric, leaving both sides of the print perfectly visible.

Did you know that all our frames come with a QR code that links to the white label installation manual?

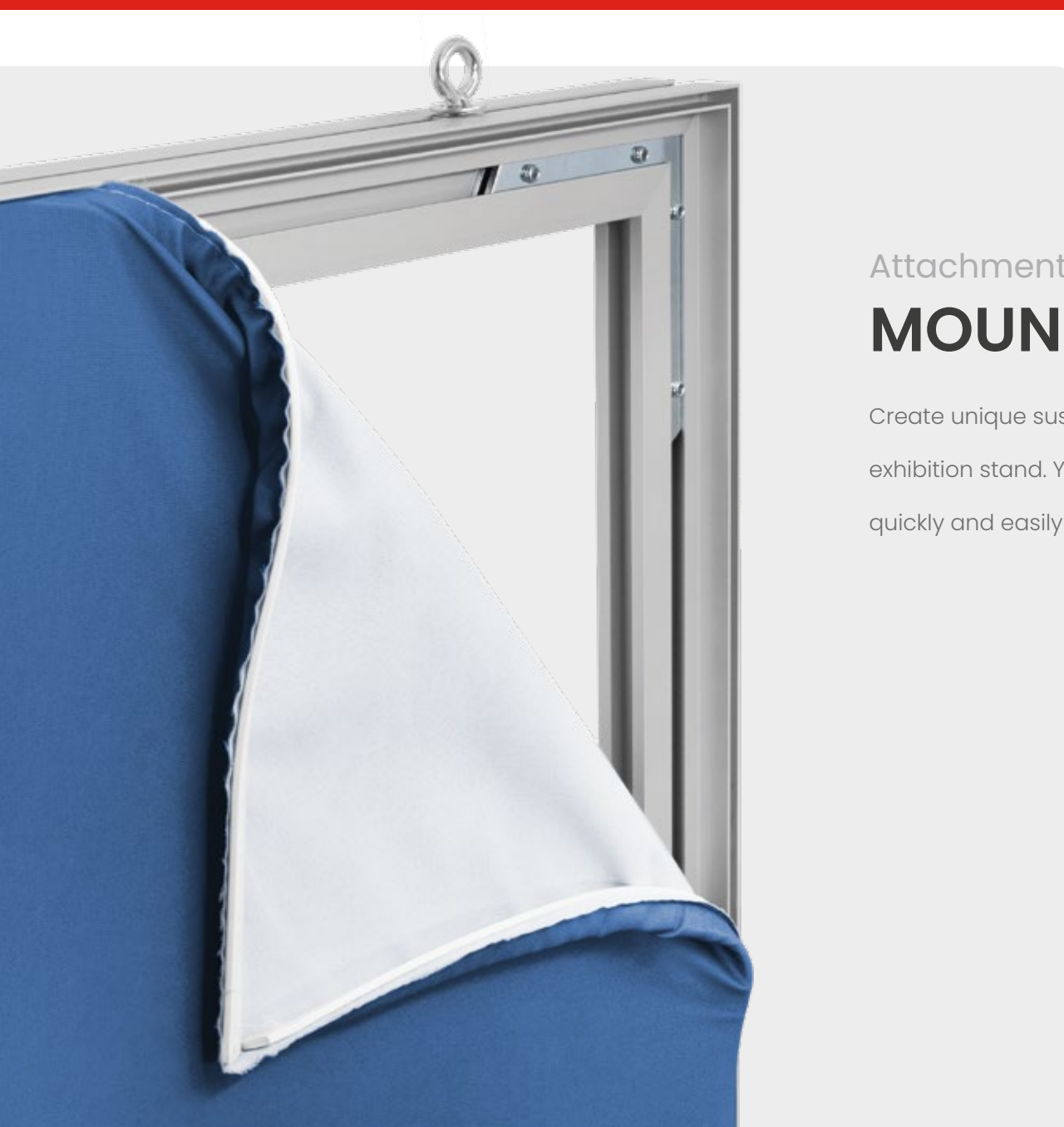

Attachment option 1

MOUNTING OPTIONS

Create unique suspended banners for in every showroom or above an exhibition stand. You can use suspension eyelets or suspension cables to quickly and easily hang up a double-sided textile frame.

*See page 134 for
all ceiling mounts* 



Ceiling mount



Suspension cable

TUV



Attachment option 2

FREESTANDING OPTIONS

Create eye-catching displays in shops or unique partitions that look perfect in any office, showroom, or exhibition floor using our baseplates. The baseplate acts as a footrest under the profile. We have baseplates available in different types, thicknesses, and sizes.

*See page 130
for all baseplates* 

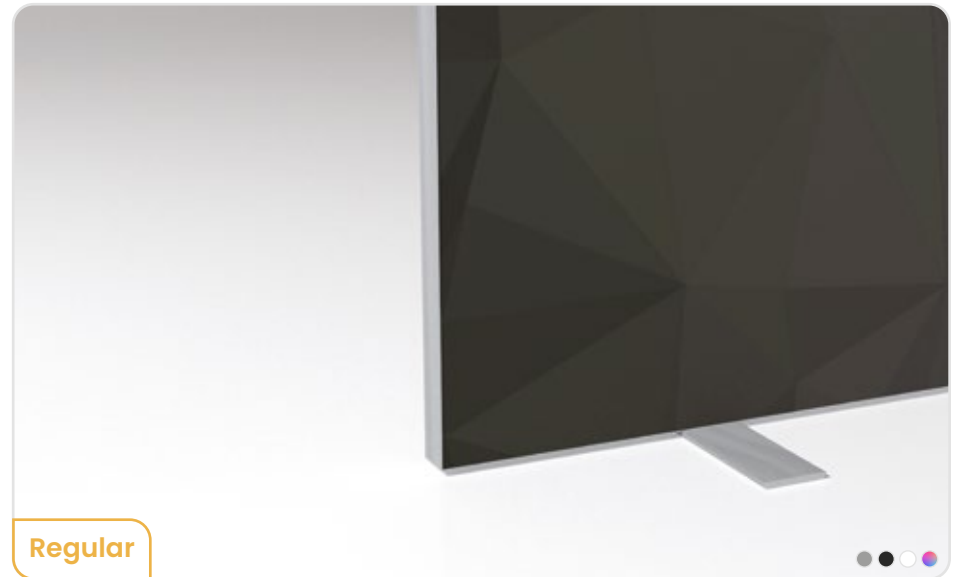



Aluminium tubular frame

1.3 OUTDOOR

Tubular frames are a well-known concept in the market: a super strong frame with an industrial look. They are suitable for all types of advertising, both indoors and outdoors and are durable. The aluminium tubes are used in combination with our steel connectors. A banner with rings can be stretched into these using tensioning elastics.



Tube 42

Tubular frame for indoor and outdoor use.

All our profiles have a white label product sheet. Download it from the product page.



Textile frames

1.4 KEDER

With the **Cord 43**, also called a 2-channel keder frame, it is possible to create banners quickly and easily. Only two aluminium Cord 43 profiles are required. The print is inserted at the top and bottom of the profile. The endcap ensures that the fabric stays in place.



Cord 43

Quickly and easily create suspended banners.

All our profiles have a white label product sheet. Download it from the product page.



Attachment option

HANGING KEDER FRAME

This profile can be provided with a textile fabric with a round keder tendon. The fabric with the flexible thick tendon is placed in the aluminium profile and finished with the supplied endcaps. The banner tendon should have a minimum thickness of 7.5 mm and a maximum thickness of 13 mm to be placed in our aluminium keder frame.





LED FRAMES

A LED frame is a textile frame fitted with LED lighting. A LED frame adds dimension and atmosphere to a room and gives it a contemporary look. Due to the development of various LED technologies, our lightboxes come in any desired size.

2.1	LED technologies	42
2.2	Single-sided	50
2.3	Double-sided	54
2.4	Dynamic LED	60
2.5	Tunable white	64
2.6	Pop-up LEDbox	66



Vizio

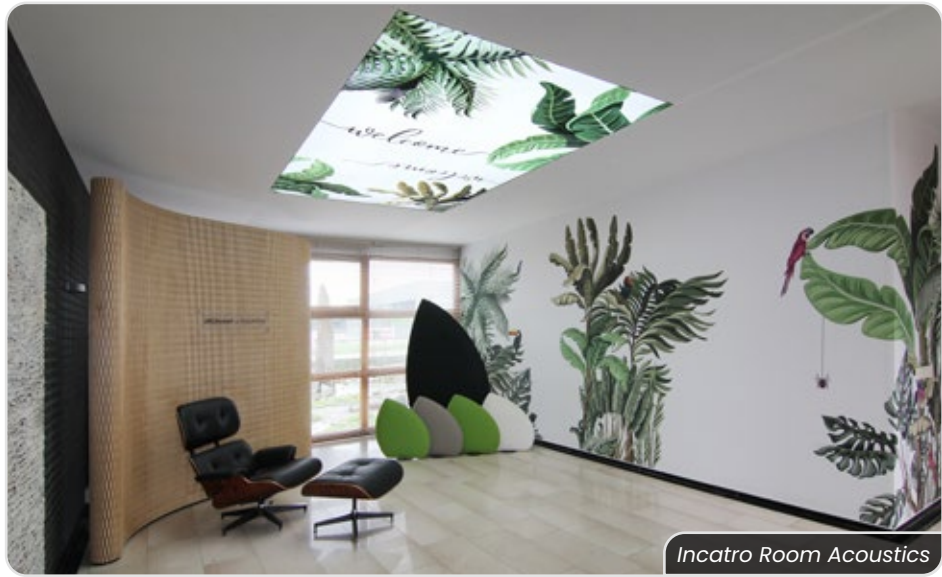

Incatro Room Acoustics





Multicopy Assen



Gielissen



Adder AB



Several

2.1 LED TECHNOLOGIES

We have various LED technologies developed. Depending on your needs, there is always a LED frame that fits. Let your message stand out with one of the featured LED technologies.



EFKA is the absolute

SPECIALIST IN LED FRAMES

It is often difficult to select a well-lit frame, what is the best choice for your specific situation? We explain to you which LED technology is best to use, depending on the application. There is always a suitable solution for every situation!

 **TWO-YEAR WARRANTY**

 **CE CERTIFIED**

 **CUSTOM WORK**





Edge-lit



EDGE-LIT LED TECHNOLOGY

Illuminates the textile print from the side using powerLED.



GOOD QUALITY/PRICE RATIO

Good light distribution for small to large formats, with a full-colour print.



ECONOMICAL TO TRANSPORT

The components of the frame can be sent as a flat package, making the frame economical to transport.



RELATIVELY LOW POWER CONSUMPTION

An advantages of Edge-lit is the relatively low power consumption.



1. Connect the corners

Slide the lockset into the profile and tighten the screws to connect two profile parts and create a corner.



2. Connect the plugs

Put the pre-assembled LED strips and drivers together.



3. Attach the frame

Mount the frame directly onto the wall or by using wall mounts. Hanging from the ceiling is also an option.



4. Place the textile print

First attach the silicone tendon in the corners of the groove. Then press the print into the rest of the groove.



Place blackout fabric - optional

The blackout fabric can be placed on the inside of the frame for better light reflection. Place the fabric into the designated groove.



Reinforces the frame - optional

To guarantee the stability of large format frames, stabilizers get mounted in the frame that acts as reinforcement.

Did you know that all our frames come with a QR code that links to the white label installation manual?



LED on Dibond



LED PRE-MOUNTED ON DIBOND

Illuminates the textile print from the back with LED pre-mounted on a dibond plate.



NARROW FRAMES POSSIBLE

The frame can be made extremely narrow, from a depth of 60 mm.



TWO LIGHT INTENSITIES AND DIMMING

You can choice between Bright LED and Super Bright LED, three light colours and the option to dim the light.



QUICK INSTALLATION

LED on Dibond frames can be installed easily and quickly as they get delivered pre-assembled.



1. Place the frame

Attach the frame to the wall.



3. Attach the textile print

First attach the silicone tendon in the corners of the groove. Then press the print into the rest of the groove.

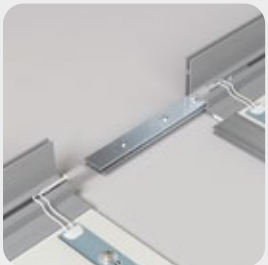

Slide the parts together - optional

Long lengths are often delivered in two or more parts. The different parts can easily be assembled with the corresponding extension set.



Connect the plugs - optional

Put the pre-assembled LED strips and drivers together.

Did you know that all our frames come with a QR code that links to the white label installation manual?



LED on Stabilizer



LED MOUNTED ONTO STABILIZERS

Illuminates the textile print from the back with LED mounted onto stabilizers.



SUITABLE FOR LARGE FORMATS

LED on Stabilizer offers satisfying illumination in all cases and is suitable for extra-large formats.



TWO LIGHT INTENSITIES AND DIMMING

You can choose between Bright LED and Super Bright LED, three light colours and the option to dim the light.



ECONOMICAL TO TRANSPORT

The components of the frame can be sent as a flat package, making the frame economical to transport.

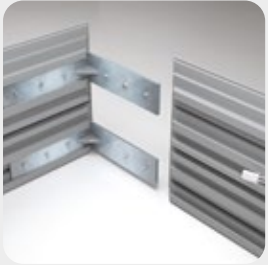

1. Connect the corners

Slide the lockset into the profile and tighten the screws to connect two profile parts and create a corner.

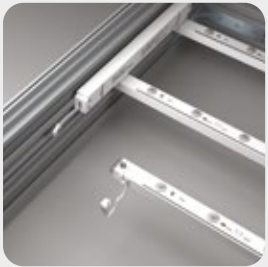

2. Install the stabilizers

Place the stabilizers, with LED, on the indicated positions.

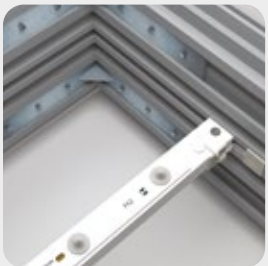

3. Connect the plugs

Put the pre-assembled LED strips and drivers together.



4. Place the frame

The frame can be mounted on the wall, placed freestanding using baseplates or suspended using ceiling mounts.



5. Attach the textile print

First attach the silicone tendon in the corners of the groove. Then press the print into the rest of the groove.

Did you know that all our frames come with a QR code that links to the white label installation manual?



LED frames

2.2 SINGLE-SIDED

We have a wide range of single-sided LED frames specially designed for wall mounting, freestanding (where one side is illuminated) and in some cases, ceiling illumination. Thanks to the clever flat-tendon system, the white or printed fabric is quick and easy to change, so you can create a new look and feel in no time.



Lightbox 60

Single-sided LED frame with backlit illumination and additional groove on the back.

- ✓ LED on Dibond



Lightbox 90

Single-sided LED frame with side lighting.

- ✓ Edge-lit
- ✓ Open and closed



Lightbox 120

Single-sided LED frame for illuminating large-format textile prints.

- ✓ Edge-lit and LED on Stabilizer
- ✓ Open and closed

All our profiles have a white label product sheet. Download it from the product page.



Single-sided

WALL MOUNTING LED FRAMES

The LED frame can be mounted on the wall for a single sided, illuminated advertising message.

*See page 133 for
all wall mounts* 



Drilling through Dibond



Drilling through profile



Wall mount



LED frames

2.3 DOUBLE-SIDED

A double-sided LED frame can be fitted with two textile prints, which can be used both freestanding and suspended. Our double-sided LED frames are often used at exhibition stands and in shops and showrooms.



Lightbox Double 100

Double-sided LED frame with side lighting.

- ✓ Open and closed
- ✓ Edge-lit



Lightbox Double 120

Double-sided LED frame with side lighting.

- ✓ Edge-lit



Lightbox Double 160

Double-sided LED frame for illuminating large-format and 3D textile prints.

- ✓ Edge-lit and LED on Stabilizer



Lightbox Double 200

Extra sturdy double-sided LED frame for extra large-format textile prints

- ✓ Edge-lit and LED on Stabilizer

All our profiles have a white label product sheet. Download it from the product page.



Attachment option 1

SUSPENDED WITH CEILING MOUNTS

Create eye-catching suspended banners and displays that look perfect in any showroom or above an exhibition stand with ceiling mounts and/or suspension cables.

*See page 134 for
all ceiling mounts* 



Ceiling mounts



Attachment option 2

FREESTANDING OPTIONS

Create eye-catching displays, standing banners or exhibition walls using our baseplates. The baseplate acts as a footrest under the profile.

*See page 130
for all baseplates* 

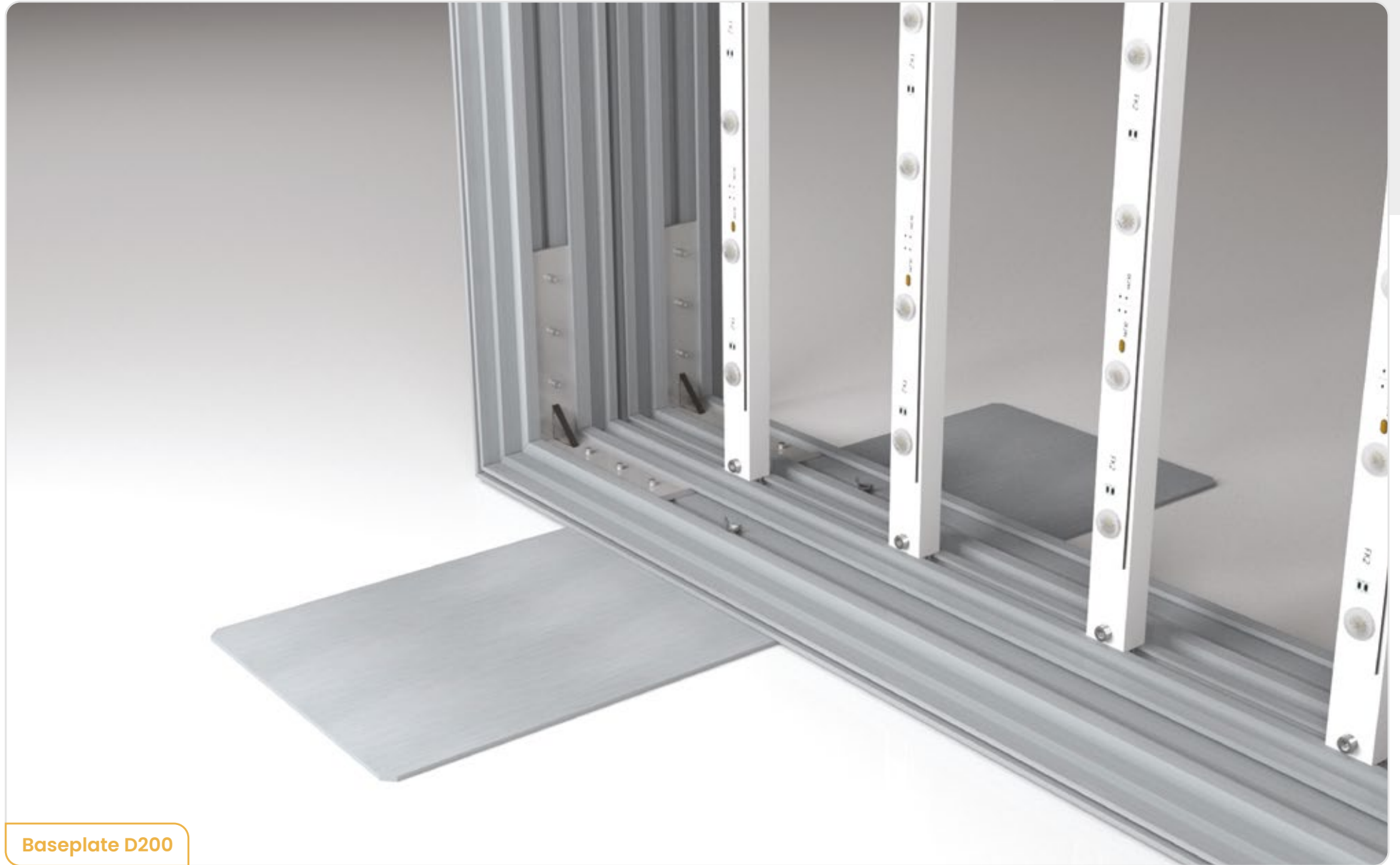

Baseplate D200



LED frames

2.4 DYNAMIC LED

Thanks to dynamic LED, you can practically bring your textile print to life. A video animation controls the illumination and therefore offers the possibility to create dynamics in a static environment. It's the perfect way for putting your brand, product, or message in the spotlight in a creative way. We have dynamic LED available in RGB (colour) and white.

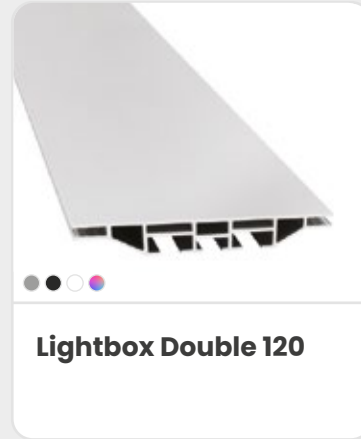
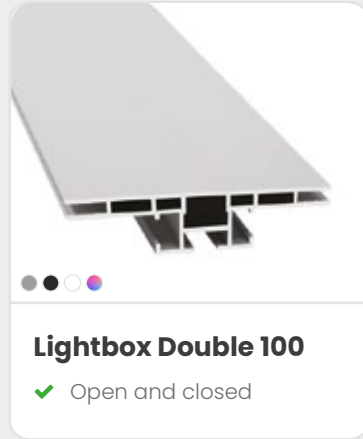

All our profiles have a white label product sheet. Download it from the product page.



Animations

LED FRAME WITH DYNAMIC LED

By using pre-programmed animations that are matched to the fabric, dynamic LED can highlight a message in an even more targeted way.

Dynamic LED

Create impressive animations

Dynamic LED

Create impressive animations



LED frames

2.5 TUNABLE WHITE

With tunable white, both the light colour and brightness can be adjusted as desired. This makes it possible to make a room multi-functional with for example: burning bright, neutral light during the day and switching to mood lighting in the evening.



All our profiles have a white label product sheet. Download it from the product page.



LED frames

2.6 POP-UP LEDBOX

The Pop-up LEDbox is a modular double-sided aluminium frame with efficient LED lighting. The compact LED frame is available in the size 1000 x 2000 mm. The frame can be assembled in just five steps without using any tools. It can be used as a pop-up exhibition wall, roll-up banner, mobile display, billboard and as signage at temporary locations.



Pop-up LEDbox

Double-sided pop-up LED frame, with a size of 100 x 200 cm.



Quick and easy

POP-UP LEDBOX

The **Pop-up LEDbox** is designed for quick transport and can be assembled without tools in just five steps. The Pop-up LEDbox is lightweight, making it easy to transport. You can connect several of these frames.



1. Turn the baseplates

Turn the two baseplates that are attached to the bottom of the frame.



2. Connect the bottom corners

Mount the two lower vertical parts of the frame to the lower part and click the corners into place with the pre-assembled mounting system.



3. Connect the top corners

Now assemble the three upper frame parts together to create a U-shape. Use the numbering on the frame as guideline.



4. Connect the bottom to the top

Place the mounted U-frame on top of the groundframe and make sure to connect the lighting units.



5. Attach the textile print

First attach the silicone tendon in the corners of the groove. Then press the print into the rest of the groove.

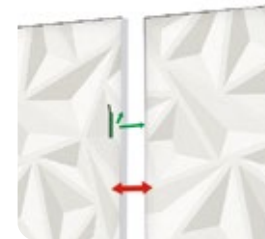

Connect several frames - optional

Combine and connect several frames with the supplied connectors.



CURVED FRAMES

Nowadays, curved textile frames are the frames that can literally and figuratively make the difference.

A curved frame adds playfulness, but it can also be used as a sleek eye-catcher. Curved textile frames are very versatile: single and double-sided, lit and unlit and in various shapes.

3.1 Non-illuminated 76

3.2 Illuminated 78





America Digitaal Druk



GRIPP Projecten





Curved frames

SINGLE-SIDED AND DOUBLE-SIDED

A curved frame on the wall, freestanding or suspended from the ceiling, distinguishes itself from the standard straight shapes that are often used.



Circle



Cylinder

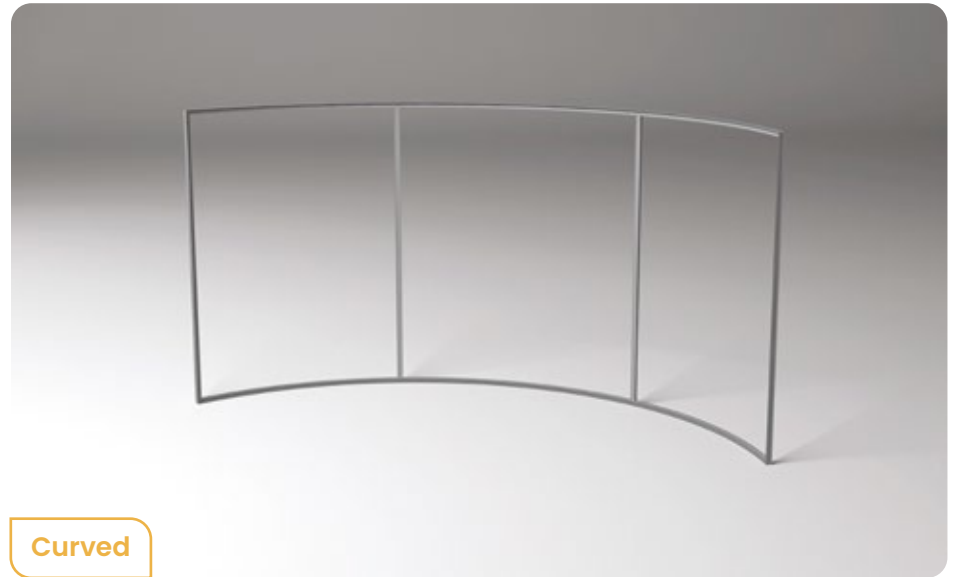

Curved



Curved frames

3.1 NON-ILLUMINATED

Create impressive and unique shapes with curved frames. Use curved LED frames, for example, to create a unique hanging banner in retail, a spectacular curved wall at trade fairs or as circle in the interior.



Simple 19

A curved budget profile for wall mounting.

- ✓ Circle and curved



Heavy 27

A sturdy, curved wall profile for wall and ceiling mounting.

- ✓ Circle, cylinder and curved



Double 44, open

A popular double-sided profile that can be used freestanding and suspended.

- ✓ Circle, cylinder and curved



Double 44, closed

A popular double-sided profile that can be used freestanding and suspended.

- ✓ Cylinder and curved



Double 80

An extra sturdy double-sided profile for freestanding and suspended applications.

- ✓ Circle, cylinder and curved
- ✓ Open and closed

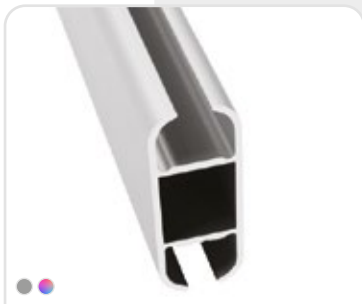

Cord 43

Quickly and easily create suspended curved banners.

- ✓ Cylinder and curved

All our profiles have a white label product sheet. Download it from the product page.



Curved frames

3.2 ILLUMINATED

We also have curved frames with lighting. As a result, the application possibilities are very diverse, making it possible to realise a striking eye-catcher for every situation. Use curved LED frames, for example, as ceiling illumination, direction indicators, exhibition stand or in the interior.



Lightbox 90

Single-sided curved LED frame with backlit illumination.

- ✓ LED on Stabilizer
- ✓ Cylinder and curved
- ✓ Open and closed



Lightbox 100

Single-sided curved LED frame with backlit illumination.

- ✓ LED on Dibond
- ✓ Circle



Lightbox Double 160

Double-sided curved LED frame with backlit illumination.

- ✓ LED on Dibond
- ✓ Circle

All our profiles have a white label product sheet. Download it from the product page.



Project 2000

3D FRAMES

3D frames are unique, compared to standard frames. The possibilities are virtually unlimited.

Our 3D frames can be used in two ways: suspended from the ceiling and freestanding. We supply 3D frames in L, U and O configurations.

4.1 Non-illuminated	86
4.2 Illuminated	98





Brandt & Fernhout

Configurations

FREESTANDING

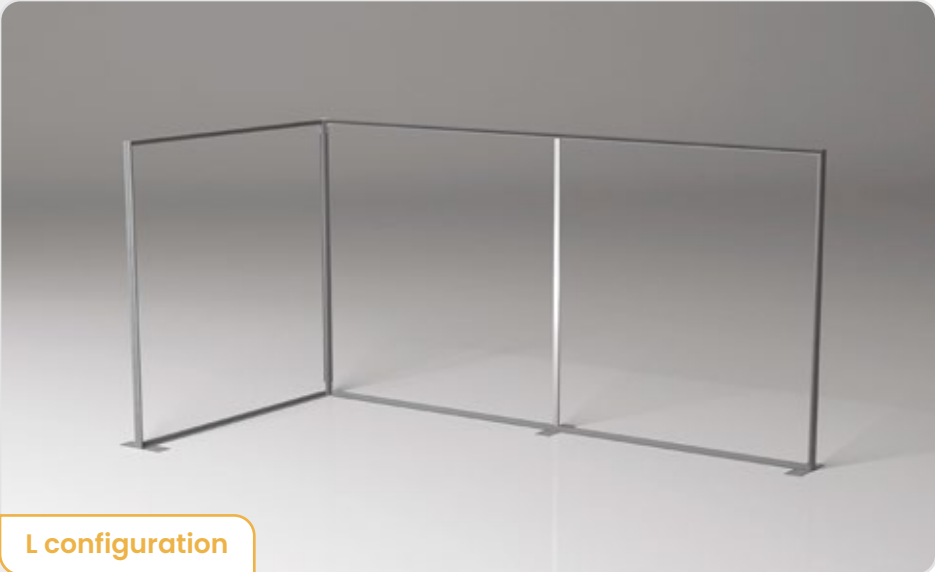

Configurations
SUSPENDED



L configuration



U configuration







O configuration





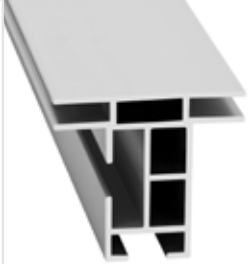

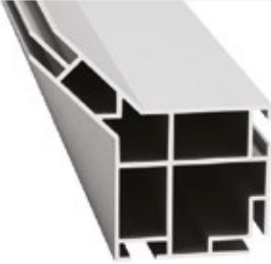
3D frames

4.1 NON-ILLUMINATED

With our 3D profiles, you can create eye-catching frames. The fitted textile print is visible from several sides and perfect for both suspended and freestanding use. The construction also lends itself to the creation of fully exhibition stands.

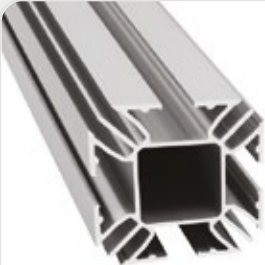
					
<p>Carre 44 A small 3D profile for creating L, O and U configurations.</p>	<p>Double 44</p>	<p>Encap carre 44</p>	<p>Carre 80 A 3D profile for creating L, O and U configurations.</p>	<p>Double 80</p>	<p>Encap carre 80</p>

				
<p>Cube 65 A lightweight cube frame for smaller formats and long rectangular shapes.</p>	<p>Corner connector</p>	<p>Quatro 50 A profile to create unique 3D banners, including large and sturdy cubes.</p>	<p>2-way corner quatro 50</p>	<p>3-way corner quatro 50</p>

All our profiles have a white label product sheet. Download it from the product page.



3D textile frame

CARRE 44 SUSPENDED & FREESTANDING

You can create unique 3D banners with the **Carre 44** profile. The combination with the **Double 40** profile makes it a sturdy and stable whole. The Carre 44 profile is perfect for both freestanding and suspended use. The profile is safe to use up to a height of 2300 mm. The width has no restrictions. For a larger format, we recommend the **Carre 80**, as it is an even thicker and sturdier profile.

*See page 134 for
all ceiling mounts* 



1. Connect the corners

Slide the lockset into the profile and tighten the screws to connect two profile parts and create a corner.



2. Place the endcaps

Finish the corners neatly by simply sliding the endcaps into the appropriate holes.

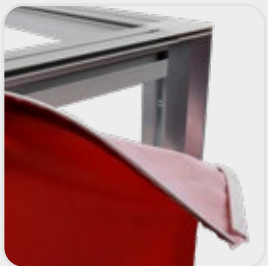

3. Attach the textile print

First attach the silicone tendon in the corners of the groove. Then press the print into the rest of the groove.

Did you know that all our frames come with a QR code that links to the white label installation manual?

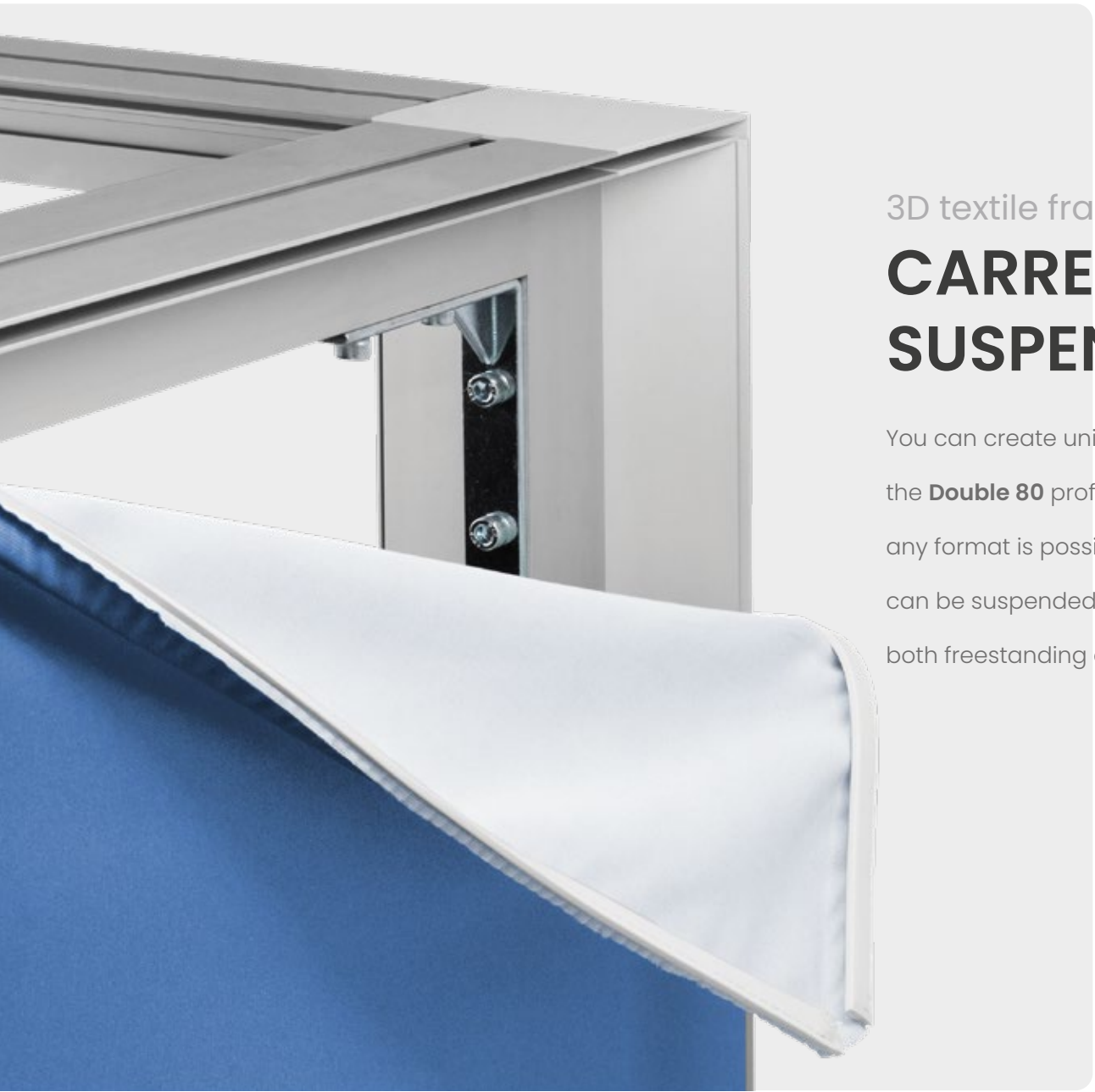

3D textile frame

CARRE 80 SUSPENDED & FREESTANDING

You can create unique 3D banners with the **Carre 80** profile. The combination with the **Double 80** profile makes it a sturdy and stable whole. By using stabilizers, almost any format is possible. By using ceiling mounts and/or suspension cables, the frame can be suspended from the ceiling. As a result, the Carre 80 profile is perfect for both freestanding and suspended use.

*See page 134 for
all ceiling mounts* 

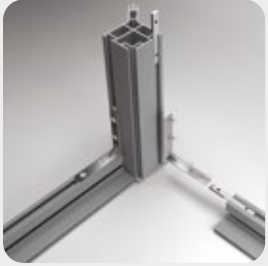

1. Connect the corners

Slide the lockset into the profile and tighten the screws to connect two profile parts and create a corner.



2. Place the endcaps

Finish the corners neatly by simply sliding the endcaps into the appropriate holes.



3. Attach the textile print

First attach the silicone tendon in the corners of the groove. Then press the print into the rest of the groove.

Did you know that all our frames come with a QR code that links to the white label installation manual?

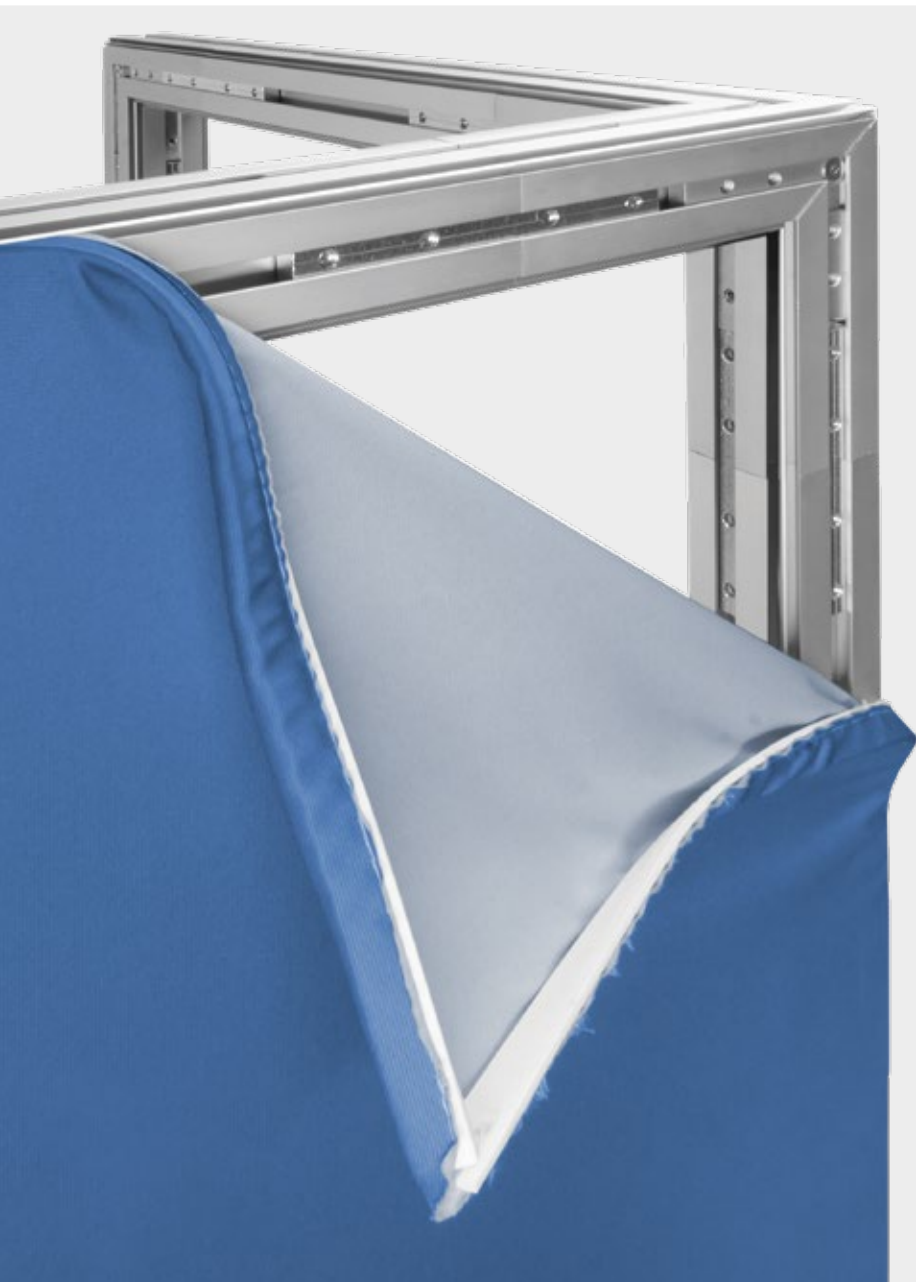

3D textile frame

QUATRO 50 SUSPENDED & FREESTANDING

You can create unique 3D banners with the **Quatro 50** profile, including large and sturdy cubes. The tendon fabric can be attached to all sides. The Quatro 50 profile is sturdy due to its shape, and it is easy to assemble with the corner connectors. By using ceiling mounts and/or suspension cables, the frame can be suspended from the ceiling. As a result, the frame is perfect for both freestanding and suspended use.

*See page 134 for
all ceiling mounts* 



1. 2-way corner quatro 50

Use the 2-way connector as a two-sided corner piece.



2. Connect the corners

Connect the corner piece with the Quatro 50 profile. Then tighten the screws with the Allen key provided.

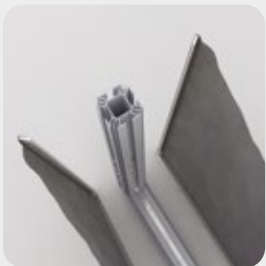

3. Attach the textile print

First attach the silicone tendon in the corners of the groove. Then press the print into the rest of the groove.



1. 3-way corner quatro 50

Use the 3-way connector as a three-sided corner piece.



2. Connect the corners

Connect the corner piece with the Quatro 50 profile. Then tighten the screws with the Allen key provided.

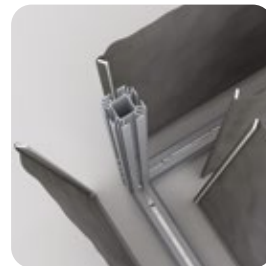

3. Attach the textile print

First attach the silicone tendon in the corners of the groove. Then press the print into the rest of the groove.

Did you know that all our frames come with a QR code that links to the white label installation manual?



3D cube frame

CUBE 65 **SUSPENDED & FREESTANDING**

The **Cube 65** is specially designed so that textile prints can be placed on all sides. The textile print fits seamlessly into the corners of the configuration for a perfectly sleek design. The profile is suitable for small formats. For a larger format than 2x2x2 metres or an extra sturdy cube, we recommend the **Quatro 50**, **Carre 44** or **Carre 80** profile.



1. Lock cube 65

Use the lock cube 65 as a three-sided corner piece.



2. Connect the corners

Connect the profile with the lock cube 65 by placing it in the Cube 65 profile.



3. Attach the textile print

First attach the silicone tendon in the corners of the groove. Then press the print into the rest of the groove.

Did you know that all our frames come with a QR code that links to the white label installation manual?



Freestanding





3D frames

4.2 ILLUMINATED

With our illuminated 3D profiles, you can create eye-catching LED frames. The fitted textile print is visible from several sides and perfect for both suspended and freestanding use. The construction also lends itself to the creation of fully exhibition stands.



Carre 160

A 3D profile to create striking illuminated L, U and O configurations.

✓ Edge-lit and LED on Stabilizer



Lightbox Double 160

All our profiles have a white label product sheet. Download it from the product page.



3D LED frame

CARRE 160 SUSPENDED & FREESTANDING

You can create spectacular illuminated walls with the **Carre 160** profile. The combination with the **Lightbox Double 160** profile makes it a sturdy and stable whole. By using stabilizers, almost any format is possible. By using ceiling mounts and/or suspension cables, the frame can be suspended from the ceiling. As a result, the Carre 160 profile is perfect for both freestanding and suspended use.

*See page 134 for
all ceiling mounts* 



1. Connect the corners

Slide the lockset into the Lightbox Double 160 profile and tighten the screws to connect two profile parts and create a corner.



2. Place the Carre 160 profile

Place the cut-to-size Carre 160 profile on the vertical part of the lockset and attach the lockset to the Carre 160 profile with the supplied fastening set.

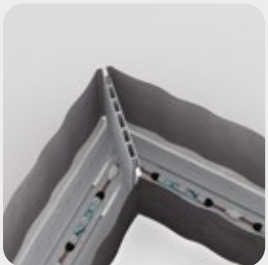

3. Attach the textile print

First attach the silicone tendon in the corners of the groove. Then press the print into the rest of the groove.

Did you know that all our frames come with a QR code that links to the white label installation manual?



PANEL FRAMES

Our Panel hanging and L-shape can be used to hang panel material, like Dibond or Forex. Whereby the frame of the Panel hanging is not visible, but with the L-shape, it serves as a frame.

5.1 Panel hanging	104
5.2 L-shape	106



Panel frames

5.1 PANEL HANGING

With the **Panel Hanging 18**, also known as a blind suspension system, you mount panels with a smooth surface to the wall. Because the frame is not visible, the print seems to float, and this way, you create a 3D effect.



Panel Hanging 18

For mounting panels without the frame being visible.

All our profiles have a white label product sheet. Download it from the product page.



Panel frames

5.2 L-SHAPE

Add the finishing touch to the panel material. The print is placed within the aluminium frame. The small space between the frame and the print gives a spacious feeling, and the simple contemporary design makes the print stand out.



L-shape 17,8

For framing a panel, with a depth of 17.8 mm.



L-shape 30

For framing a panel, with a depth of 30 mm.

All our profiles have a white label product sheet. Download it from the product page.



ACOUSTICS

Good acoustics are becoming increasingly important in creating a pleasant living and working space. Poor acoustics can be extremely tiring, and noise pollution for a longer period can even harm your health. By placing acoustic material in a frame, you improve the acoustics in a room. Annoying sounds such as reverberation, echoes and hollow sounds in a room are muffled, creating a peaceful (working) environment.

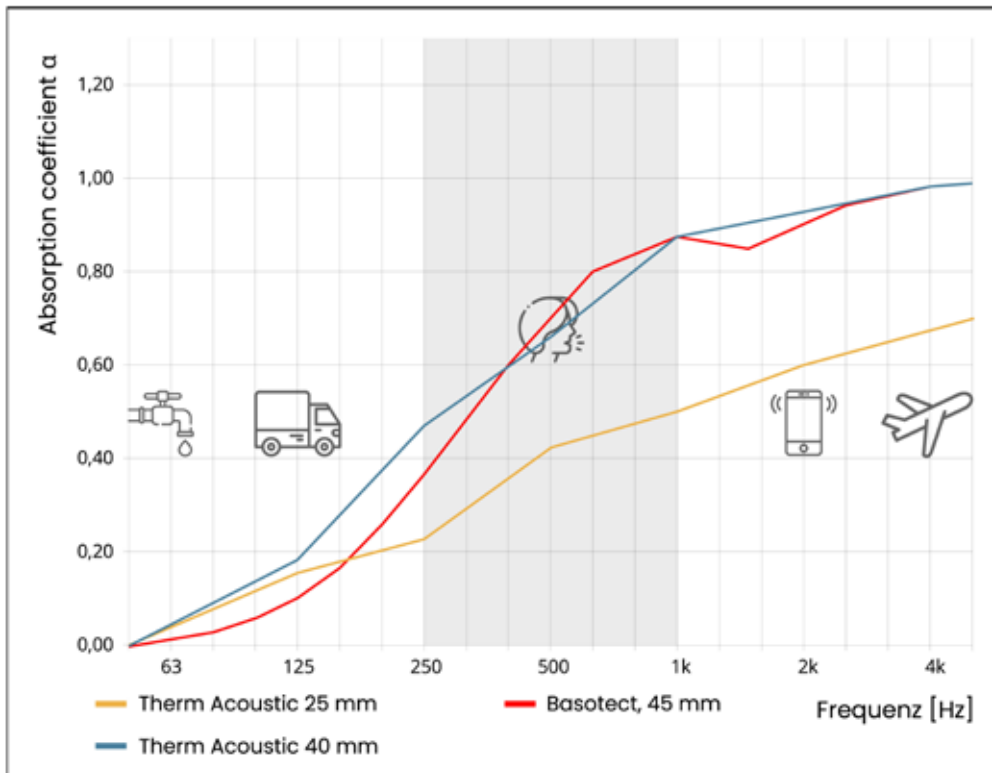

Acoustics

6.1 ABSORPTION VALUE

The quality of an acoustic material is determined by its absorption value. This value indicates how much sound is absorbed. The most ideal value is 1, which corresponds to 100% absorption. The area marked in grey is the speech area; this is usually the focus for an average room.



Basotect®

Very light and rigid acoustic material with a high absorption value.

- ✓ 45 mm
- ✓ Fire class B1



Therm Acoustic

A 100 percent recyclable acoustic material with a good absorption value.

- ✓ 10, 25 and 40 mm
- ✓ Fire class B1
- ✓ Recyclable



PRODUCT OVERVIEW

7.1	Profiles	114
7.2	Acoustics	125
7.3	Locksets	126
7.4	Extension sets	128
7.5	Baseplates	130
7.6	Wall mounts	133
7.7	Ceiling mounts	134
7.8	Corners	134
7.9	Connectors	135
7.10	Tension sets	136
7.11	Desk clamps	137
7.12	Other	137

Eco 15

0.286 kilos/metre

Locksets:
FK-0210 / FK-0212
FK-0214 / FK-0218

Extension sets:
FK-0510



NF-04150

↔ 6150 mm

● Silver



NF-21150

↔ 6150 mm

● Black



NF-56150

↔ 6150 mm

○ White



NF-04150PH

↔ 6150 mm

● Silver

Pre-drilled



NF-21150PH

↔ 6150 mm

● Black

Pre-drilled



NF-56150PH

↔ 6150 mm

○ White

Pre-drilled

Simple 19

0.318 kilos/metre

Locksets:
FK-0210 / FK-0212
FK-0214 / FK-0218

Extension sets:
FK-0510



NF-04190

↔ 6150 mm

● Silver



NF-21190

↔ 6150 mm

● Black



NF-56190

↔ 6150 mm

○ White



NF-04190PH

↔ 6150 mm

● Silver

Pre-drilled



NF-21190PH

↔ 6150 mm

- Black
- 🔧 Pre-drilled



NF-56190PH

↔ 6150 mm

- White
- 🔧 Pre-drilled

Slim 25

📦 0.476 kilos/metre

⚙️ Locksets:
FK-0210 / FK-0212
FK-0214 / FK-0218

Extension sets:
FK-0510



25 mm
28 mm



NF-04250

↔ 6150 mm

- Silver



NF-21250

↔ 6150 mm

- Black



NF-56250

↔ 6150 mm

- White



NF-04250PH

↔ 6150 mm

- Silver
- 🔧 Pre-drilled



NF-21250PH

↔ 6150 mm

- Black
- 🔧 Pre-drilled



NF-56250PH

↔ 6150 mm

- White
- 🔧 Pre-drilled

Heavy 26 45°

📦 0.985 kilos/metre

⚙️ Locksets:
FK-0200 / FK-0202
FK-0205 / FK-0430

Extension sets:
FK-0500 / FK-0532



26 mm
60 mm



NF-04070-45G

↔ 6150 mm

- Silver



NF-21070-45G

↔ 6150 mm

- Black



NF-56070-45G

↔ 6150 mm

○ White

Heavy 27

📦 0.677 kilos/metre

⚙️ Locksets:
FK-0200 / FK-0202
FK-0205 / FK-0430

Extension sets:
FK-0500 / FK-0532



NF-04270

↔ 6150 mm

● Silver



NF-21270

↔ 6150 mm

● Black



NF-56270

↔ 6150 mm

○ White

Single 50

📦 0.968 kilos/metre

⚙️ Locksets:
FK-0200 / FK-0205
FK-0202

Extension sets:
FK-0500 / FK-0532



NF-04502

↔ 6150 mm

● Silver



NF-21502

↔ 6150 mm

● Black



NF-56502

↔ 6150 mm

○ White

Cabinet 30

📦 0.286 kilos/metre

⚙️ Locksets:
FK-0260



NF-04340

↔ 6150 mm

● Silver

✂️ Built-in



NF-21340

↔ 6150 mm

● Black

✂️ Built-in

Double 44

1.081 kilos/metre (closed)
0.785 kilos/metre (open)

Locksets:
FK-0200 / FK-0202
FK-0205 / FK-0430

Extension sets:
FK-0500 / FK-3054



NF-04445

↔ 6150 mm

● Silver

☒ Closed



NF-21445

↔ 6150 mm

● Black

☒ Closed



NF-56445

↔ 6150 mm

○ White

☒ Closed



NF-04440

↔ 6150 mm

● Silver

☒ Open



NF-21440

↔ 6150 mm

● Black

☒ Open



NF-56440

↔ 6150 mm

○ White

☒ Open

Double 50

1.039 kilos/metre (closed)
0.987 kilos/metre (open)

Locksets:
FK-0200 / FK-0202
FK-0205 / FK-0430

Extension sets:
FK-0500 / FK-0532

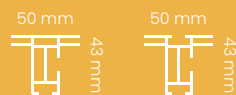

NF-04515

↔ 6150 mm

● Silver

☒ Closed



NF-21515

↔ 6150 mm

● Black

☒ Closed



NF-56515

↔ 6150 mm

○ White

☒ Closed



NF-04510

↔ 6150 mm

● Silver

☒ Open



NF-21510

↔ 6150 mm

● Black

☒ Open



NF-56510

↔ 6150 mm

○ White

☒ Open

Double 80

📦 1.369 kilos/metre (closed)
1.332 kilos/metre (open)

⚙️ Locksets:
FK-0200 / FK-0202
FK-0205 / FK-0430

Extension sets:
FK-0500 / FK-0532

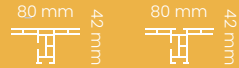

NF-04805

↔ 6150 mm

● Silver

☒ Closed



NF-21805

↔ 6150 mm

● Black

☒ Closed



NF-56805

↔ 6150 mm

○ White

☒ Closed



NF-04800

↔ 6150 mm

● Silver

☒ Open



NF-21800

↔ 6150 mm

● Black

☒ Open



NF-56800

↔ 6150 mm

○ White

☒ Open

Double 100

📦 1.415 kilos/metre

⚙️ Locksets:
FK-0240

Extension sets:
FK-0522



NF-041000

↔ 6150 mm

● Silver

☒ Closed



NF-211000

↔ 6150 mm

● Black

☒ Closed



NF-561000

↔ 6150 mm

○ White

☒ Closed

Tube 42

📦 0.690 kilos/metre

⚙️ Locksets:
FK-0410

Extension sets:
FK-4030



NF-05042

↔ 6150 mm

● Mill finish



NF-21042

↔ 6150 mm

● Black

Cord 43

📦 0.462 kilos/metre

⚙️ Locksets:
FK-0605 / FK-0606
FK-0607 / FK-0608

Endcap:
FK-0604

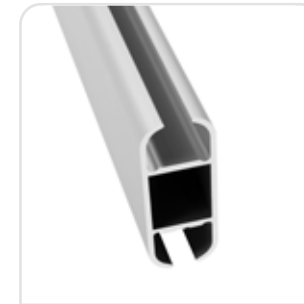

NF-04434

↔ 6150 mm

● Silver

Lightbox 60

📦 1.018 kilos/metre

⚙️ Locksets:
FK-0200 / FK-0202
FK-0205 / FK-0430

Extension sets:
FK-0500 / FK-0532



NF-04604

↔ 6150 mm

● Silver



NF-21604

↔ 6150 mm

● Black



NF-56604

↔ 6150 mm

○ White

Lightbox 90

📦 1.934 kilos/metre (closed)
1.895 kilos/metre (open)

⚙️ Locksets:
FK-0200 / FK-0202
FK-0205 / FK-0430

Extension sets:
FK-0500 / FK-0532



NF-04905

↔ 6150 mm

● Silver

☒ Closed



NF-21905

↔ 6150 mm

● Black

☒ Closed



NF-56905

↔ 6150 mm

○ White

☒ Closed



NF-04900

↔ 6150 mm

● Silver

☒ Open

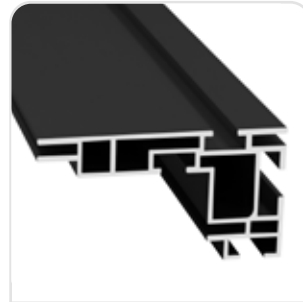

NF-21900

↔ 6150 mm

● Black

☒ Open



NF-56900

↔ 6150 mm

○ White

☒ Open

Lightbox 120

📦 2.150 kilos/metre (closed)
2.221 kilos/metre (open)

⚙️ Locksets:
FK-0250

📏 Extension sets:
FK-0500 / FK-0532

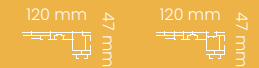

NF-041205

↔ 6150 mm

● Zilver

☒ Closed



NF-211205

↔ 6150 mm

● Black

☒ Closed



NF-561205

↔ 6150 mm

○ White

☒ Closed



NF-041200

↔ 6150 mm

● Silver

☒ Open



NF-211200

↔ 6150 mm

● Black

☒ Open



NF-561200

↔ 6150 mm

○ White

☒ Open

Lightbox Double 100

1.386 kilos/metre (closed)
1.347 kilos/metre (open)

Locksets:
FK-0240

Extension sets:
FK-0522



NF-041012

↔ 6150 mm

● Silver

☒ Closed



NF-211012

↔ 6150 mm

● Black

☒ Closed



NF-561012

↔ 6150 mm

○ White

☒ Closed



NF-041002

↔ 6150 mm

● Silver

☒ Open



NF-211002

↔ 6150 mm

● Black

☒ Open



NF-561002

↔ 6150 mm

○ White

☒ Open

Lightbox Double 120

1.543 kilos/metre

Locksets:
FK-1200

Extension sets:
FK-0534



NF-041250

↔ 6150 mm

● Silver

☒ Closed



NF-211250

↔ 6150 mm

● Black

☒ Closed



NF-561250

↔ 6150 mm

○ White

☒ Closed

Lightbox Double 160

2.005 kilos/metre

Locksets:
FK-1200

Extension sets:
FK-0534

160 mm
17 mm



NF-041600

↔ 6150 mm

● Silver

☒ Closed



NF-211600

↔ 6150 mm

● Black

☒ Closed



NF-561600

↔ 6150 mm

○ White

☒ Closed

Lightbox Double 200

2.873 kilos/metre

Locksets:
FK-0230

Extension sets:
FK-0530

200 mm
24 mm



NF-042000

↔ 6150 mm

● Silver

☒ Closed



NF-212000

↔ 6150 mm

● Black

☒ Closed



NF-562000

↔ 6150 mm

○ White

☒ Closed

Pop-up LEDbox

9.5 kilos (100 x 200 cm)

80 mm
18 mm



LC-04100200

100 x 200 cm

● Silver

✓ Including a box

Carre 44

1.033 kilos/meter

Locksets:
FK-0285

Endcap:
FK-0720

50,8 mm
50,8 mm



NF-05447

↔ 6150 mm

● Mill finish

Carre 80

2.206 kilos/meter

Locksets:
FK-0280

Endcap:
FK-0725

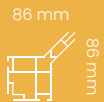

NF-04810

↔ 6150 mm

● Silver

Quatro 50

1.476 kilos/metre

Corners:
FK-0752 / FK-0753

Extension sets:
FK-3054

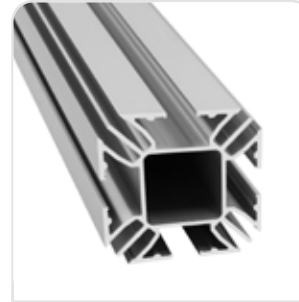
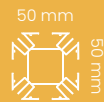

OF-04500

↔ 6150 mm

● Silver

Cube 65

0.879 kilos/metre

Locksets:
FK-0710

Extension sets:
FK-0715



NF-04650

↔ 6150 mm

● Silver

Carre 160

3.458 kilos/metre

Locksets:
FK-1200 / FK-0675

Extension sets:
FK-0540



NF-041602

↔ 6150 mm

● Silver

Panel Hanging 18

0.357 kilos/metre

Locksets:
FK-0210 / FK-0218



NF-04183

↔ 6150 mm

● Silver

L-shape 17,8

0.202 kilos/metre

Locksets:
FK-0210 / FK-0212
FK-0214 / FK-0218

Extension sets:
FK-0510



NF-04178

↔ 6150 mm

● Silver

L-shape 30

0.3 kilos/metre

Locksets:
FK-0210 / FK-0212
FK-0214 / FK-0218

Extension sets:
FK-0510

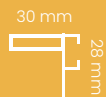

NF-04300

↔ 6150 mm

● Silver



NF-21300

↔ 6150 mm

● Black

Stabilizer 43

0.425 kilos/metre

Locksets:
FK-0220 / FK-0222



NF-04438

↔ 6150 mm

● Silver

Round stabilizer

0.312 kilos/metre

Locksets:
FK-0220S



NF-56210

↔ 6150 mm

○ White

Mini stabilizer

0.338 kilos/metre

Locksets:
FK-0220S



NF-56240

↔ 6150 mm

○ White

Dibond connector

0.186 kilos/metre



NF-56280

↔ 6150 mm

○ White

Dibond adapter

0.118 kilos/metre



NF-04310

↔ 6150 mm

● Silver

Acoustics

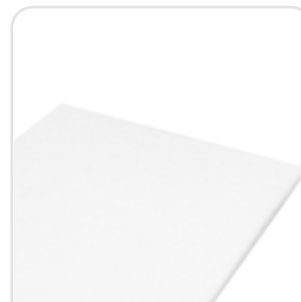

FK-8930

➤ Therm Acoustic

↗ 10 mm

🔥 Fire class B1

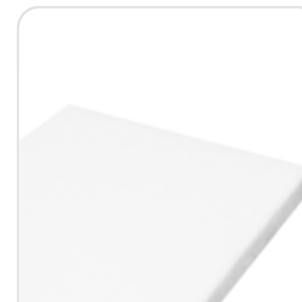

FK-8910

➤ Therm Acoustic

↗ 25 mm

🔥 Fire class B1



FK-8920

➤ Therm Acoustic

↗ 40 mm

🔥 Fire class B1



FK-8950

➤ Basotect®

↗ 45 mm

🔥 Fire class B1

Locksets



FK-0175

- Lockset round corner 50
- Silver



FK-2175

- Lockset round corner 50
- Black



FK-5675

- Lockset round corner 50
- White



FK-0200

- Lockset heavy
- Silver



FK-0202

- Lockset heavy single plate
- Silver



FK-0205

- Lockset heavy short
- Silver



FK-0210

- Lockset simple
- Silver



FK-0212

- Lockset simple single plate
- Silver



FK-0214

- Lockset simple large single plate
- Silver



FK-0218

- Lockset simple with allen key
- Silver



FK-0220

- Lockset stabilizer
- Silver



FK-0220S

- Lockset mini stabilizer
- Silver



FK-0222

- Lockset stabilizer 45°
- Silver



FK-0230

- Lockset 200
- Silver



FK-0240

- Lockset 100
- Silver



FK-0250

- Lockset 120
- Silver



FK-0260

- Lockset cabinet
- Silver



FK-0270

- Lockset cube stabilizer
- Silver



FK-0285

- Lockset carre 44
- Silver



FK-0280

- Lockset carre 80
- Silver



FK-0430

- Flexibele lockset
- Silver



FK-0675

- Lockset carre 160
- Silver



FK-0710

- Lock cube 65
- Silver

Extension sets



FK-0730

- Lock round corner 44
- Silver



FK-1200

- Lockset 120/160
- Silver



FK-1220

- Toolles lock
- Silver



FK-4010

- Lock tube 42
- Silver



FK-4015

- Lock tube 42
- Black



FK-0500

- Extension set heavy
- Silver



FK-0510

- Extension set eco/simple
- Silver



FK-0520

- Extension set 100
- Silver



FK-0522

- Extension set double 100
- Silver



FK-0530

- Extension set 200
- Silver



FK-0532

- Extension set aluminium keeper
- Silver



FK-0534

- Extension set double 120/160
- Silver



FK-0540

- Extension set carre 160
- Silver



FK-0605

- Connector cord 43
- Silver



FK-0606

- Hinged connector cord 43
- Silver



FK-0607

- Extension cord 43
- Silver



FK-0608

- Extension cord 43 R2000
- Silver

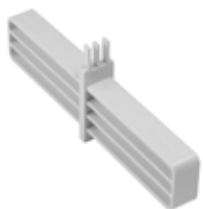

FK-0715

- Extension cube 65
- Silver



FK-1230

- Toolless extension
- Silver



FK-3050

- Connectorset quatro 50
- Silver



FK-3054

- Extension set quatro 50
- Silver



FK-4030

- Extension tube 42
- Silver



FK-4035

- Extension tube 42
- Black

Baseplates



FK-0100

- Baseplate simple
- Silver
- ✂ 380 x 50 x 10 mm
- 📦 405 grams



FK-0105

- Baseplate slim
- Silver
- ✂ 380 x 75 x 3 mm
- 📦 675 grams



FK-2105

- Baseplate slim
- Black
- ✂ 380 x 75 x 3 mm
- 📦 675 grams



FK-5605

- Baseplate slim
- White
- ✂ 380 x 75 x 3 mm
- 📦 675 grams

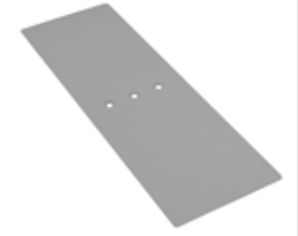

FK-0110

- Baseplate heavy
- Silver
- ✂ 450 x 150 x 3 mm
- 📦 1085 grams



FK-2110

- Baseplate heavy
- Black
- ✂ 450 x 150 x 3 mm
- 📦 1085 grams



FK-5610

- Baseplate heavy
- White
- ✂ 450 x 150 x 3 mm
- 📦 1085 grams



FK-0110HN

- Baseplate heavy HN
- Silver
- ✂ 245 x 150 x 3 mm
- 📦 852 grams



FK-2110HN

- Baseplate heavy HN
- Black
- ✂ 245 x 150 x 3 mm
- 📦 852 grams



FK-5610HN

- Baseplate heavy HN
- White
- ✂ 245 x 150 x 3 mm
- 📦 852 grams



FK-0140

- Baseplate D200
- Silver
- ✂ 600 x 200 x 3 mm
- 📦 2820 grams

**FK-2140**

➤ Baseplate D200

● Black

✂ 600 x 200 x 3 mm

📦 2820 grams

**FK-5640**

➤ Baseplate D200

○ White

✂ 600 x 200 x 3 mm

📦 2820 grams

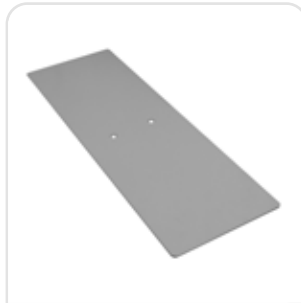
**FK-0145**

➤ Baseplate heavy M

● Silver

✂ 600 x 200 x 3 mm

📦 2801 grams

**FK-2145**

➤ Baseplate heavy M

● Black

✂ 600 x 200 x 3 mm

📦 2801 grams

**FK-5645**

➤ Baseplate heavy M

○ White

✂ 600 x 200 x 3 mm

📦 2801 grams

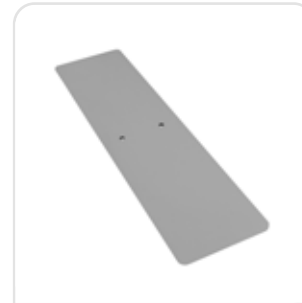
**FK-0176**

➤ Baseplate heavy XL

● Silver

✂ 800 x 200 x 5 mm

📦 6400 grams

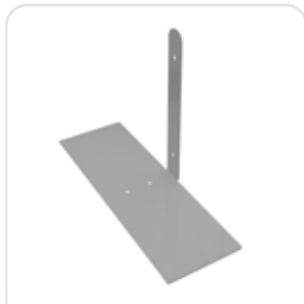
**FK-0120**

➤ Baseplate side

● Silver

✂ 450 x 150 x 3 mm

📦 1880 grams

**FK-2120**

➤ Baseplate side

● Black

✂ 450 x 150 x 3 mm

📦 1880 grams

**FK-5620**

➤ Baseplate side

○ White

✂ 450 x 150 x 3 mm

📦 1880 grams

**FK-0120HL**

➤ Baseplate side HL

● Silver

✂ 245 x 150 x 3 mm

📦 1120 grams

**FK-2120HL**

➤ Baseplate side HL

● Black

✂ 245 x 150 x 3 mm

📦 1120 grams

**FK-5620HL**

➤ Baseplate side HL

○ White

✂ 245 x 150 x 3 mm

📦 1120 grams

**FK-0120HR**

- Baseplate side HR
- Silver
- ⊠ 245 x 150 x 3 mm
- 📦 1120 grams

**FK-2120HR**

- Baseplate side HR
- Black
- ⊠ 245 x 150 x 3 mm
- 📦 1120 grams

**FK-5620HR**

- Baseplate side HR
- White
- ⊠ 245 x 150 x 3 mm
- 📦 1120 grams

**FK-0130**

- Baseplate side heavy
- Silver
- ⊠ 600 x 200 x 3 mm
- 📦 3075 grams

**FK-2130**

- Baseplate side heavy
- Black
- ⊠ 600 x 200 x 3 mm
- 📦 3075 grams

**FK-5630**

- Baseplate side heavy
- White
- ⊠ 600 x 200 x 3 mm
- 📦 3075 grams

**FK-2130**

- Baseplate side heavy XL
- Silver
- ⊠ 800 x 200 x 5 mm
- 📦 7500 grams

**FK-0181**

- Baseplate wheel small
- Silver
- ⊠ 450 x 100 x 5 mm
- 📦 1973 grams

**FK-2181**

- Baseplate wheel small
- Black
- ⊠ 450 x 100 x 5 mm
- 📦 1973 grams

**FK-0185**

- Baseplate side wheel small
- Silver
- ⊠ 450 x 100 x 5 mm
- 📦 2239 grams

**FK-2185**

- Baseplate side wheel small
- Black
- ⊠ 450 x 100 x 5 mm
- 📦 2239 grams

Wall mounts



FK-0400

- Wall mount simple (2 pieces)
- Silver
- ⊠ 30 x 30 x 15 mm



FK-0410

- Wall mount heavy (2 pieces)
- Silver
- ⊠ 40 x 40 x 20 mm



FK-0414

- Wall mount 120 (2 pieces)
- Silver
- ⊠ 40 x 40 x 25 mm



FK-0440

- Wall mount bracket
- Silver
- ⊠ 200 x 70 x 50 mm



FK-0442

- Wall mount 44
- Silver
- ⊠ 40 x 40 x 20 mm



FK-0443

- Wall mount 50
- Silver
- ⊠ 40 x 40 x 22 mm



FK-4020

- Wall mount tube 42
- Silver
- ↔ 200 mm



FK-4025

- Wall mount tube 42
- Black
- ↔ 500 mm



FK-8020

- Cleathanger 20
- Silver
- ↔ 200 mm



FK-8050

- Cleathanger 50
- Silver
- ↔ 500 mm



FK-8120

- Cleathanger 120
- Silver
- ↔ 1200 mm

Ceiling mounts



FK-0360

- Ceiling mount
- Silver



FK-0420

- Ceiling mount slim
- Silver



FK-0422

- Ceiling mount slim suspension
- Silver
- ↓ 3 metre cable



FK-0425

- Ceiling mount heavy
- Silver



FK-0427

- Ceiling mount heavy suspension
- Silver
- ↓ 3 metre cable



FK-0609

- Cord 43 hanger
- Silver

TUV



FK-7900

- Suspension cable (2 pieces)
- Silver
- ↓ 4 metre cable

TUV



FK-7905

- Suspension cable (2 pieces)
- Silver
- ↓ 10 metre cable

Corners



FK-0604

- Endcap cord 43
- Silver



FK-0720

- Endcap carre 44
- Silver



FK-0721

➤ Endcap carre 44

- Black



FK-0722

➤ Endcap carre 44

- White



FK-0725

➤ Endcap carre 80

- Silver



FK-0726

➤ Endcap carre 80

- Black



FK-0727

➤ Endcap carre 80

- White



FK-0752

➤ 2-way corner quatro 50

- Silver



FK-0753

➤ 3-way corner quatro 50

- Silver



FK-0810

➤ Corner protector 44

- White

Connectors



FK-0610

➤ Stabilizer connector

- Silver



FK-0620

➤ Frame connector 135°

- Silver



FK-0630

➤ Frame connector 90°

- Silver



FK-0640

- Frame connector 180°
- Silver



FK-0650

- T-frame connector
- Silver



FK-0660

- Cross frame connector
- Silver



FK-0668

- Frame connector
- Silver



FK-0670

- Triangle connector set
- Silver

Tension sets



FK-0446

- Tension set double 44
- Silver
- ↔ 10 mm



FK-2146

- Tension set double 27
- Black
- ↔ 10 mm



FK-5646

- Tension set double 27
- White
- ↔ 10 mm



FK-0444

- Tension set double 44
- Silver
- ↔ 10 mm



FK-2144

- Tension set double 44
- Black
- ↔ 10 mm



FK-5644

- Tension set double 44
- White
- ↔ 10 mm

Desk clamps



FK-0195

➤ Desk clamp
(2 pieces)

● Silver



FK-2195

➤ Desk clamp
(2 pieces)

● Black



FK-5695

➤ Desk clamp
(2 pieces)

○ White



FK-0196

➤ Desk clamp left and
right (2 pieces)

● Silver



FK-2196

➤ Desk clamp left and
right (2 pieces)

● Black



FK-5696

➤ Desk clamp left and
right (2 pieces)

○ White

Other



FK-0300

➤ Alu nut

● Silver



FK-0306

➤ Steel nut

● Silver



FK-0310

➤ M6 screw

● Silver

↔ 12.55 mm



FK-0320

➤ M6 screw

● Silver

↔ 8.5 mm



FK-8815

- Nitto tape
- Black
- ⊠ 15 mm x 30 m (role)



FK-8830

- Nitto tape
- Black
- ⊠ 30 mm x 30 m (role)



FK-8932

- Kit extreme tack
- 🧰 310 ml



FK-9994

- Aluminium sample box



LED COMPONENTS

8.1 LED strips and panels	141
8.2 Drivers	145
8.3 Controllers	146
8.4 Cables	147
8.5 LED spots	148

LED strips and panels



AF90-010

- Powered
- 💡 3 lenses 2.1W / 24V
- ✂ 157 x 25 x 15 mm
- ✳ 6500K, white
- 🔊 Dimmable



AF90-011

- Powered
- 💡 6 lenses 2.1W / 24V
- ✂ 313 x 25 x 15 mm
- ✳ 6500K, white
- 🔊 Dimmable



AF90-012

- Powered
- 💡 9 lenses 2.1W / 24V
- ✂ 470 x 25 x 15 mm
- ✳ 6500K, white
- 🔊 Dimmable



AF90-015

- Powered
- 💡 9 lenses 2.7W / 24V
- ✂ 470 x 25 x 15 mm
- ✳ 6500K, white
- 🔊 Not dimmable



AF90-016

- Powered
- 💡 3 lenses 2.7W / 24V
- ✂ 157 x 25 x 15 mm
- ✳ 6500K, white
- 🔊 Not dimmable



AF90-017

- Powered
- 💡 6 lenses 2.7W / 24V
- ✂ 313 x 25 x 15 mm
- ✳ 6500K, white
- 🔊 Not dimmable



AF90-035

- Powered
- 💡 9 lenses 2.1W / 24V
- ✂ 470 x 25 x 15 mm
- ✳ 6500K, white
- 🔊 Not dimmable



AF90-040

- Powered
- 💡 3 lenses 2.1W / 24V
- ✂ 157 x 25 x 15 mm
- ✳ 6500K, white
- 🔊 Not dimmable



AF90-045

- Powered
- 💡 6 lenses 2.1W / 24V
- ✂ 313 x 25 x 15 mm
- ✳ 6500K, white
- 🔊 Not dimmable



AF90-115

- Powered
- 💡 3 lenses 1.2W / 24V
- ✂ 150 x 21.5 x 15 mm
- ✳ 6500K, white
- 🔊 Not dimmable



AF90-120

- Powered
- 💡 6 lenses 1.2W / 24V
- ✂ 320 x 21.5 x 15 mm
- ✳ 6500K, white
- 🔊 Not dimmable



AF90-125

- Poweredled
- 💡 9 lenses 1.2W / 24V
- 📏 480 x 21.5 x 15 mm
- ✳️ 6500K, white
- 🔊 Not dimmable



AF90-130

- Poweredled
- 💡 18 lenses 1.2W / 24V
- 📏 940 x 21.5 x 15 mm
- ✳️ 6500K, white
- 🔊 Not dimmable



AF90-056

- Tunable LED strip
- 💡 4 lenses 3.72W / 24V
- 📏 320 x 20 x 7.5 mm
- ✳️ 2500 - 6500K, white
- 🔊 Dimmable



AF90-057

- Tunable LED strip
- 💡 6 lenses 3.72W / 24V
- 📏 480 x 20 x 7.5 mm
- ✳️ 2500 - 6500K, white
- 🔊 Dimmable



AF90-058

- Tunable LED strip
- 💡 12 lenses 7.44W / 24V
- 📏 960 x 20 x 7.5 mm
- ✳️ 2500 - 6500K, white
- 🔊 Dimmable



AF92-005

- FK7 LED strip
- 💡 2 lenses 3.2W / 24V
- 📏 160 x 20 x 8.5 mm
- ✳️ 6500K, white
- 🔊 Dimmable



AF92-010

- FK7 LED strip
- 💡 3 lenses 3.2W / 24V
- 📏 240 x 20 x 8.5 mm
- ✳️ 6500K, white
- 🔊 Dimmable



AF92-015

- FK7 LED strip
- 💡 6 lenses 6.4W / 24V
- 📏 480 x 20 x 8.5 mm
- ✳️ 6500K, white
- 🔊 Dimmable



AF92-020

- FK7 LED strip
- 💡 12 lenses 15W / 24V
- 📏 960 x 20 x 8.5 mm
- ✳️ 6500K, white
- 🔊 Dimmable



AF92-105

- FK7 LED strip
- 💡 2 lenses 3.2W / 24V
- 📏 160 x 20 x 8.5 mm
- ✳️ 4000K, white
- 🔊 Dimmable



AF92-110

- FK7 LED strip
- 💡 3 lenses 3.2W / 24V
- 📏 240 x 20 x 8.5 mm
- ✳️ 4000K, white
- 🔊 Dimmable



AF92-115

- FK7 LED strip
- 💡 6 lenses 6.4W / 24V
- 📏 480 x 20 x 8.5 mm
- ✳️ 4000K, white
- 🔊 Dimmable

**AF92-120**

- FK7 LED strip
- 💡 12 lenses 15W / 24V
- 📏 960 x 20 x 8.5 mm
- ✳️ 4000K, white
- 🔊 Dimmable

**AF92-125**

- FK7 LED strip
- 💡 2 lenses 3.2W / 24V
- 📏 160 x 20 x 8.5 mm
- ✳️ 3000K, white
- 🔊 Dimmable

**AF92-130**

- FK7 LED strip
- 💡 3 lenses 3.2W / 24V
- 📏 240 x 20 x 8.5 mm
- ✳️ 3000K, white
- 🔊 Dimmable

**AF92-135**

- FK7 LED strip
- 💡 6 lenses 6.4W / 24V
- 📏 480 x 20 x 8.5 mm
- ✳️ 3000K, white
- 🔊 Dimmable

**AF92-140**

- FK7 LED strip
- 💡 12 lenses 15W / 24V
- 📏 960 x 20 x 8.5 mm
- ✳️ 3000K, white
- 🔊 Dimmable

**AF92-405**

- FK2-C LED strip
- 💡 2 lenses 1.44W / 24V
- 📏 130 x 16 x 8.5 mm
- ✳️ 6500K, white
- 🔊 Dimmable

**AF92-407**

- FK2-C LED strip
- 💡 3 lenses 2.88W / 24V
- 📏 210 x 16 x 8.5 mm
- ✳️ 6500K, white
- 🔊 Dimmable

**AF92-410**

- FK2-C LED strip
- 💡 4 lenses 2.88W / 24V
- 📏 290 x 16 x 8.5 mm
- ✳️ 6500K, white
- 🔊 Dimmable

**AF92-412**

- FK2-C LED strip
- 💡 5 lenses 4.32W / 24V
- 📏 370 x 16 x 8.5 mm
- ✳️ 6500K, white
- 🔊 Dimmable

**AF92-415**

- FK2-C LED strip
- 💡 6 lenses 4.32W / 24V
- 📏 450 x 16 x 8.5 mm
- ✳️ 6500K, white
- 🔊 Dimmable

**AF92-420**

- FK2-C LED strip
- 💡 12 lenses 8.6W / 24V
- 📏 930 x 16 x 8.5 mm
- ✳️ 6500K, white
- 🔊 Dimmable

**AF93-305**

- FK2 LED strip
- 💡 2 lenses 1.44W / 24V
- 📏 130 x 20 x 8.5 mm
- ✳️ 3000K, white
- 🔊 Dimmable

**AF93-307**

- FK2 LED strip
- 💡 3 lenses 2.88W / 24V
- 📏 210 x 20 x 8.5 mm
- ✳️ 3000K, white
- 🔊 Dimmable

**AF93-310**

- FK2 LED strip
- 💡 4 lenses 2.88W / 24V
- 📏 290 x 20 x 8.5 mm
- ✳️ 3000K, white
- 🔊 Dimmable

**AF93-312**

- FK2 LED strip
- 💡 5 lenses 4.32W / 24V
- 📏 370 x 20 x 8.5 mm
- ✳️ 3000K, white
- 🔊 Dimmable

**AF93-315**

- FK2 LED strip
- 💡 6 lenses 4.32W / 24V
- 📏 450 x 20 x 8.5 mm
- ✳️ 3000K, white
- 🔊 Dimmable

**AF93-320**

- FK2 LED strip
- 💡 12 lenses 8.64W / 24V
- 📏 930 x 20 x 8.5 mm
- ✳️ 3000K, white
- 🔊 Dimmable

**AF93-325**

- FK2 LED strip
- 💡 2 lenses 1.44W / 24V
- 📏 130 x 20 x 8.5 mm
- ✳️ 4000K, white
- 🔊 Dimmable

**AF93-327**

- FK2 LED strip
- 💡 3 lenses 2.88W / 24V
- 📏 210 x 20 x 8.5 mm
- ✳️ 4000K, white
- 🔊 Dimmable

**AF93-330**

- FK2 LED strip
- 💡 4 lenses 2.88W / 24V
- 📏 290 x 20 x 8.5 mm
- ✳️ 4000K, white
- 🔊 Dimmable

**AF93-332**

- FK2 LED strip
- 💡 5 lenses 4.32W / 24V
- 📏 370 x 20 x 8.5 mm
- ✳️ 4000K, white
- 🔊 Dimmable

**AF93-335**

- FK2 LED strip
- 💡 6 lenses 4.32W / 24V
- 📏 450 x 20 x 8.5 mm
- ✳️ 4000K, white
- 🔊 Dimmable

**AF93-340**

- FK2 LED strip
- 💡 12 lenses 8.64W / 24V
- 📏 930 x 20 x 8.5 mm
- ✳️ 4000K, white
- 🔊 Dimmable

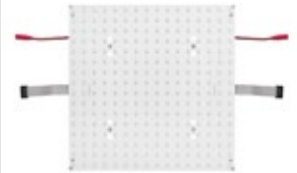
**AF92-426**

- Dynamic LED panel white
- 💡 5W / 7V
- 📏 320 x 320 mm
- ✳️ 6500K, white

Drivers

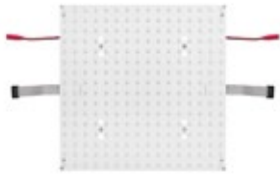

AF92-428

- Dynamic LED panel
RGB
- 💡 5W / 7V
- 📏 320 x 320 mm
- ✳️ RGB



AF99-146

- LED driver
- 💡 150W / 24V



AF99-338-WC

- LED driver FK2 / FK2-C
- 💡 30W / 24V
- 🔌 With cable



AF99-340

- LED driver
- 💡 60W / 24V



AF99-340-BP

- LED driver
- 💡 60W / 24V
- 📦 Bulk packaging



AF99-340-WC

- LED driver FK2 / FK2-C
- 💡 60W / 24V
- 🔌 With cable



AF99-342

- LED driver
- 💡 75W / 24V



AF99-342-BP

- LED driver
- 💡 75W / 24V
- 📦 Bulk packaging



AF99-342-WC

- LED driver FK2 / FK2-C
- 💡 75W / 24V
- 🔌 With cable



AF99-344

- LED driver
- 💡 100W / 24V



AF99-344-BP

- LED driver
- 💡 100W / 24V
- 📦 Bulk packaging

Controllers



AF99-344-WC

- LED driver FK2 / FK2-C
- 💡 100W / 24V
- 🔌 With cable



AF99-346-BP

- LED driver
- 💡 200W / 24V
- 📦 Bulk packaging



AF92-255

- LED remote tunable multi-zone



AF92-265

- LED remote tunable standard



AF92-290

- LED controller tunable



AF92-300

- LED repeater tunable



AF92-430

- LED controller dynamic white



AF92-432

- LED controller dynamic RGB



AF99-105

- LED controller + remote powered



AF99-112

- LED repeater FK2 / FK2-C / FK7



AF92-235

- LED controller + remote FK2 / FK2-C / FK7

**AF99-114**

- RGB LED repeater
FK2 / FK2-C / FK7

**AF92-240**

- RGB LED controller +
remote FK2 / FK2-C
/ FK7

**AF92-250**

- LED controller DALI
FK2 / FK2-C / FK7

Cables**AF90-100**

- Extension cable FK2
/ FK2-C
- ↔ 1000 mm

**AF99-212**

- Extension cable
powered
- ↔ 1000 mm

**AF90-105**

- Extension cable
tunable
- ↔ 1000 mm

**AF90-220**

- Master cable FK2 /
FK2-C
- ↔ 320 mm

**AF90-230**

- Master cable FK2 /
FK2-C
- ↔ 400 mm

**AF90-240**

- Master cable FK2 /
FK2-C
- ↔ 500 mm

**AF90-250**

- Master cable FK2 /
FK2-C
- ↔ 600 mm

**AF90-260**

- Master cable FK2 /
FK2-C
- ↔ 720 mm

**AF90-420**

- Master cable FK7
- ↔ 320 mm

**AF90-430**

- Master cable FK7
- ↔ 400 mm

**AF90-440**

- Master cable FK7
- ↔ 500 mm

**AF90-450**

- Master cable FK7
- ↔ 600 mm

**AF90-460**

- Master cable FK7
- ↔ 720 mm

**FK-8200**

- Wire cord clip (100 pieces)
- ☒ 19 x 19 x 3.9 mm

**FK-8210**

- Wire cord clip (100 pieces)
- ☒ 19 x 19 x 8 mm

**FK-8220**

- Wire cord clip (100 pieces)
- ☒ 19 x 19 x 8.7 mm

LED spots**AF99-310**

- LED spot
- 💡 10W / 8V
- ☒ 475 x 14 x 5 mm
- Silver

**AF99-312**

- LED spot
- 💡 10W / 8V
- ☒ 475 x 14 x 5 mm
- Black



Coloured frame

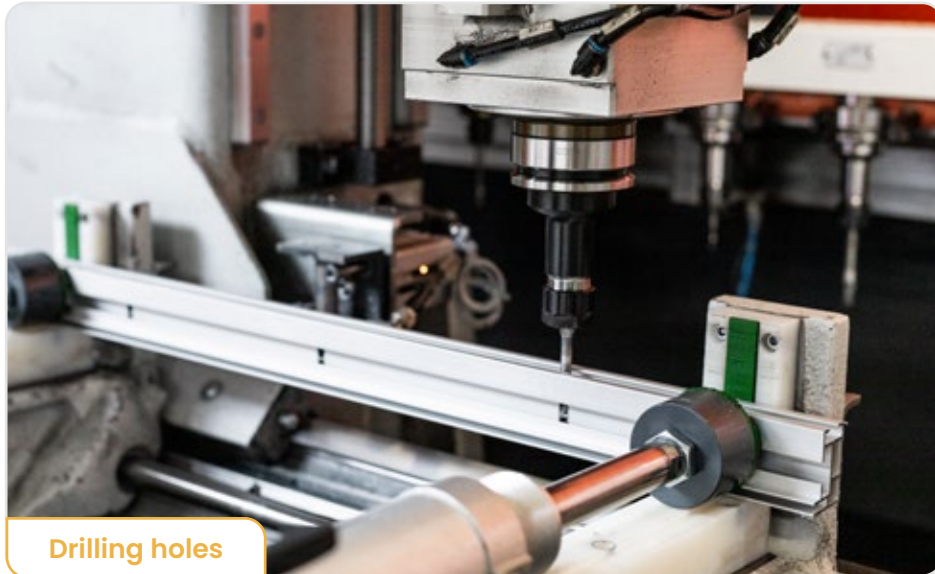

Drilling holes



Engrave

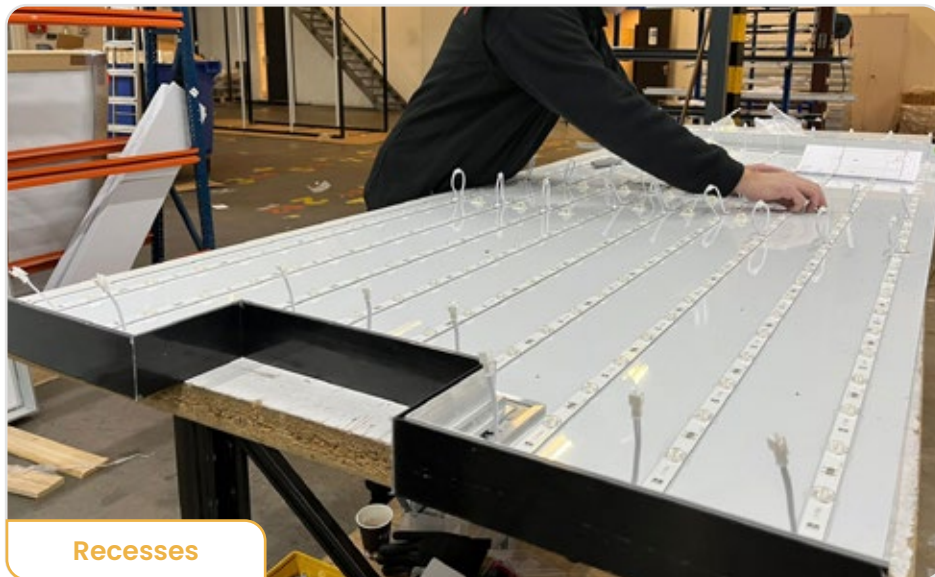

Recesses



Global Office

EFKA B.V.

De Meerpaal 10
9206 AJ Drachten
The Netherlands

+31 512 47 27 21
sales@efka.nl
www.efka.nl

Regional Office

EFKA Frame Solutions Ltd.

Unit 25, Sycamore Road
Trent Lane Industrial Estate
Castle Donington, DE74 2NP
United Kingdom

+44 1332 228 150
sales@efka.co.uk
www.efka.co.uk